

# MONOGRAM 30" STAINLESS STORAGE DRAWER

ZXS900PSNSS

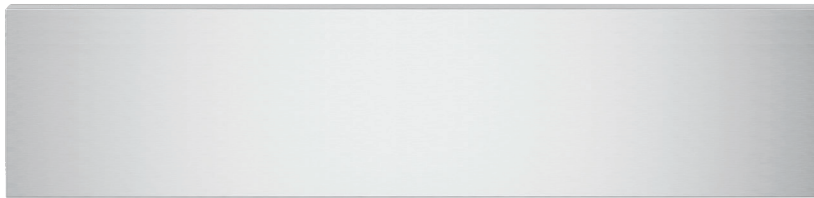

---

## THE MONOGRAM STATEMENT COLLECTION

The gleaming stainless steel finish brings traditional style with unparalleled performance.

### LARGE-CAPACITY STORAGE DRAWER

Offering a contemporary yet functional design, this spacious 1.9 cu. ft. drawer stores all your cookware beautifully.

### PUSH-TO-OPEN DRAWER

Handle-free, push-to-open drawer adds a touch of elegant simplicity and stylish convenience.

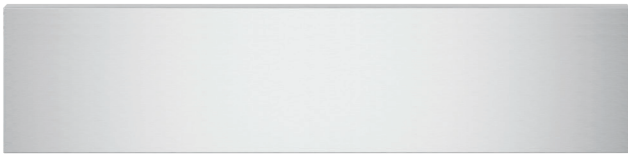

### SPECIFICATIONS

Overall Width	29 3/4" (75.5 cm)
Overall Height	6 11/16" (16.9 cm)
Overall Depth	23 7/16" (59.5 cm)
Drawer Capacity	1.90 cu. ft. (53.8 l)
Standard Cut-out Width	28 1/2" (72.4 cm)
Standard Cut-out Height	5 5/16" (15.1 cm)
Standard Cut-out Depth	22 1/8" (53.6 cm)
Net Weight	54 lbs. (24.5 kg)
Approx. Shipping Weight	60 lbs. (27.2 kg)

### OVERALL DIMENSIONS

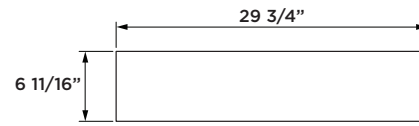

PRODUCT FRONT VIEW

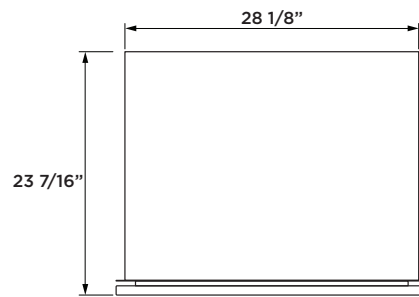

PRODUCT TOP VIEW

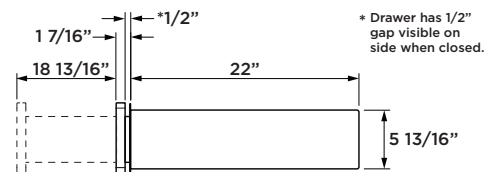

PRODUCT SIDE VIEW

\* Drawer has 1/2" gap visible on side when closed.

For more details refer to the installation instructions for this product.

Actual product dimensions may vary due to manufacturing tolerances.

### STANDARD INSTALLATION

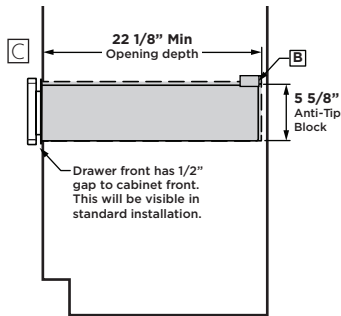

STANDARD INSTALLATION  
SIDE VIEW

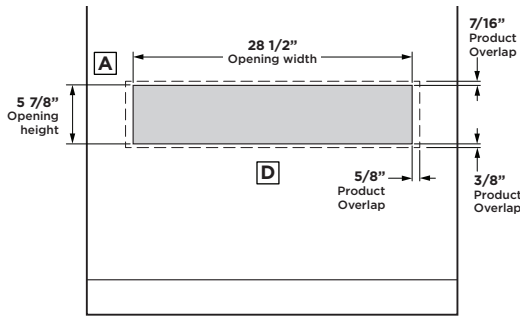

STANDARD INSTALLATION  
FRONT VIEW

### FLUSH INSET INSTALLATION

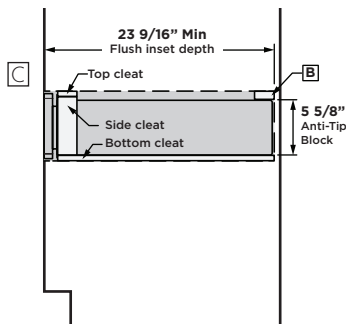

FLUSH INSET INSTALLATION  
SIDE VIEW

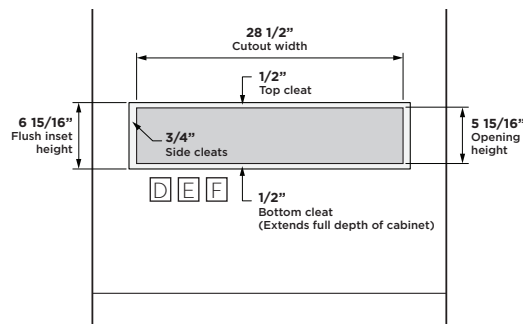

FLUSH INSET INSTALLATION  
FRONT VIEW

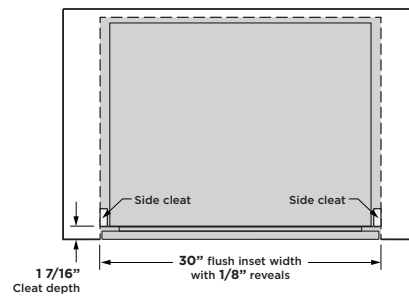

FLUSH INSET INSTALLATION  
TOP VIEW

### HELPFUL TIPS

- A** If you are installing in frameless cabinets, it may be necessary to install 1/2" wide cleats to accept drawer mounting screws. See drawer for mounting screw locations.
- B** Install an anti-tip block against rear wall, 5 5/8" from floor of cutout to bottom of block. The anti-tip block must be installed to prevent the drawer from tipping forward when opened and loaded. Failure to add the anti-tip block could result in personal injury.
- C** When installing the storage drawer below a cabinet drawer, a solid barrier must be installed at least above the storage drawer to block access. Use any solid material such as 1/4" thick plywood. Allow at least 1/4" air gap between the barrier and the top of the storage drawer. Observe the 3/8" min. above the toe kick installation height.
- D** The storage drawer may be supported by either a solid bottom or 2"x2" or 2"x4" runners. The support must be level and rigidly mounted, flush with the bottom edge of the cut-out (there is no way to level the drawer once it has been installed, so make sure that the supports are level). The floor or runners must be capable of supporting at least 65 lbs.
- E** Cabinet surfaces must be an appearance finished surface for flush installation.
- F** Cleats may be visible and should be finished to match cabinetry.

For more details refer to the installation instructions for this product.

## INSTALLATION BELOW COOKTOP

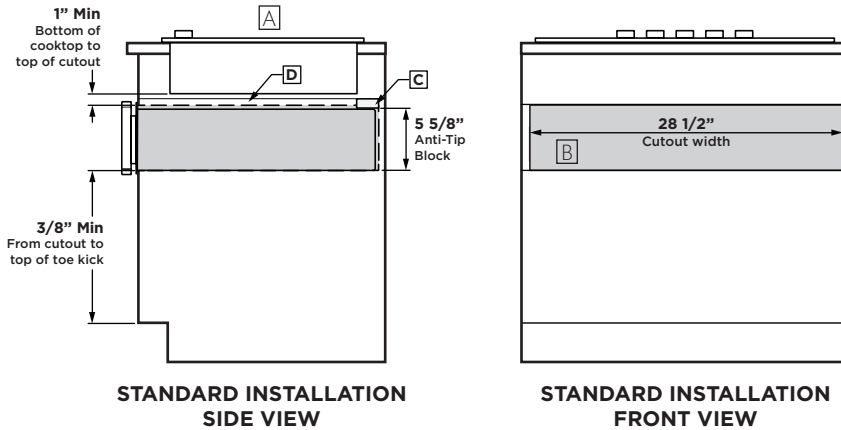

## SIDE BY SIDE INSTALLATION

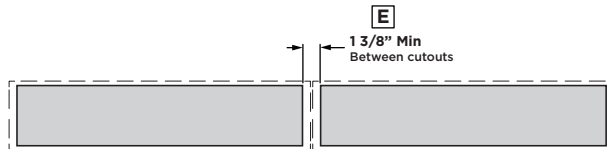

## HELPFUL TIPS

- A** Additional clearance between cut-outs may be required. Check to be sure that oven supports above the storage drawer location do not obstruct the required interior 23-1/2" depth and 5-7/8" height.
- B** If you are installing in frameless cabinets, it may be necessary to install 1/2" wide cleats to accept drawer mounting screws. See drawer for mounting screw locations.
- C** Install an anti-tip block against rear wall, 5 5/8" from floor of cutout to bottom of block. The anti-tip block must be installed to prevent the drawer from tipping forward when opened and loaded. Failure to add the anti-tip block could result in personal injury.
- D** When installing the storage drawer below a cooktop, a solid barrier must be installed at least 1" from the lowest point of the bottom of cooktop burner box to the top of the cut-out. Use any solid material such as 1/4" thick plywood. Allow at least 1/4" air gap between the barrier and the top of the storage drawer. Observe the 3/8" min. above the toe kick installation height.
- E** When installing two storage drawers side by side, install them in separate cut-outs and allow a 1-3/4" min. gap between each cut-out.

For more details refer to the installation instructions for this product.

### INSTALLATION WITH BOTTOM TRIM

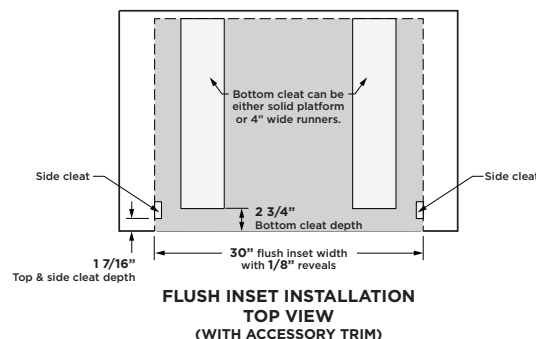
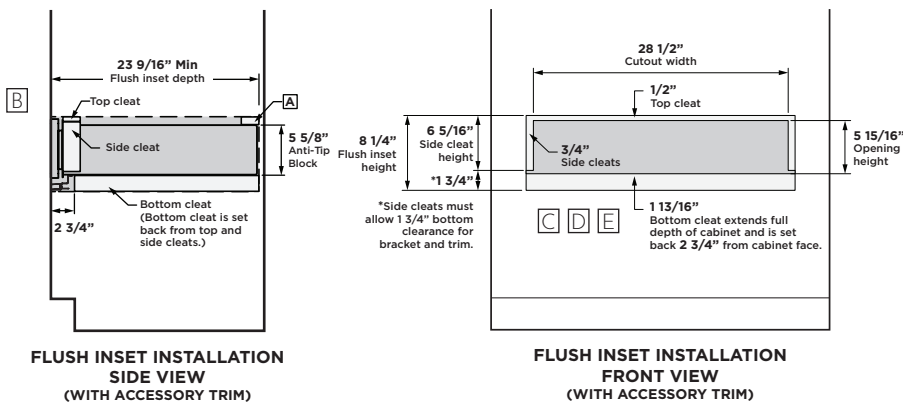
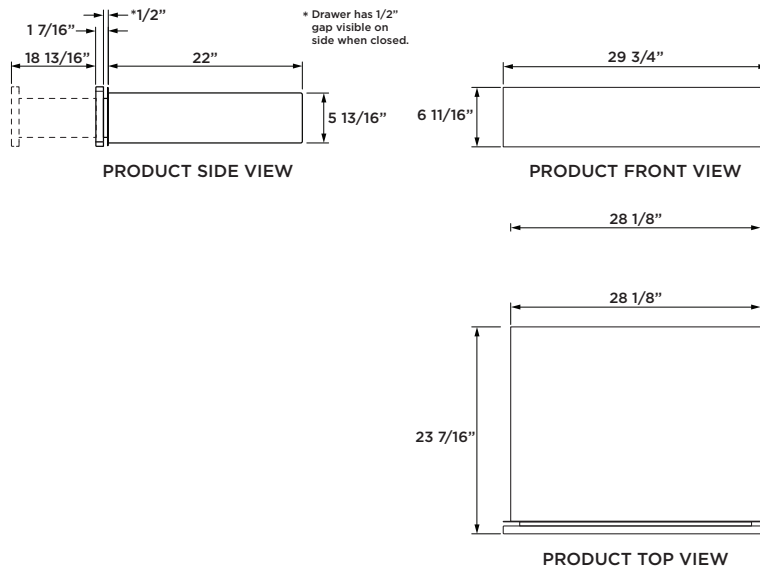

### HELPFUL TIPS

- A** Install an anti-tip block against rear wall, 5 5/8" from floor of cutout to bottom of block. The anti-tip block must be installed to prevent the drawer from tipping forward when opened and loaded. Failure to add the anti-tip block could result in personal injury.
- B** When installing the storage drawer below a cabinet drawer, a solid barrier must be installed at least above the storage drawer to block access. Use any solid material such as 1/4" thick plywood. Allow at least 1/4" air gap between the barrier and the top of the storage drawer. Observe the 3/8" min. above the toe kick installation height.
- C** The storage drawer may be supported by either a solid bottom or 2"x2" or 2"x4" runners. The support must be level and rigidly mounted, flush with the bottom edge of the cut-out (there is no way to level the drawer once it has been installed, so make sure that the supports are level). The floor or runners must be capable of supporting at least 65 lbs.
- D** Cabinet surfaces must be an appearance finished surface for flush installation.
- E** Cleats may be visible and should be finished to match cabinetry.

For more details refer to the installation instructions for this product.

INSTALLATION WITH STATEMENT WALL OVEN  
AND STATEMENT ADVANTIUM

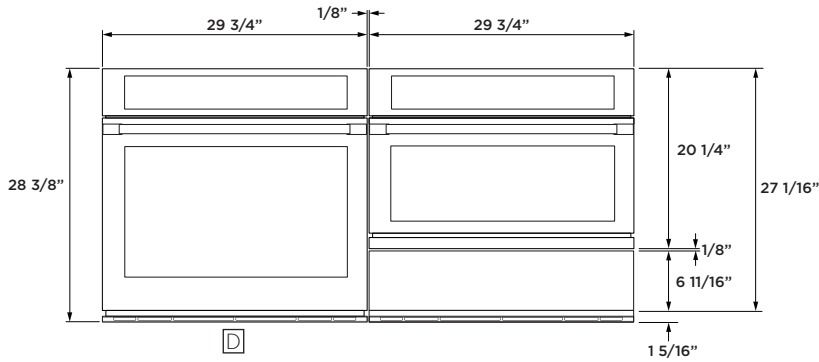

PRODUCT FRONT VIEW  
(WALL OVEN & DRAWER HAVE ACCESSORY FLUSH WALL OVEN TRIM)

HELPFUL TIPS

- A** Install an anti-tip block against rear wall, 5 5/8" from floor of cutout to bottom of block. The anti-tip block must be installed to prevent the drawer from tipping forward when opened and loaded. Failure to add the anti-tip block could result in personal injury.
- B** The storage drawer may be supported by either a solid bottom or 2"x2" or 2"x4" runners. The support must be level and rigidly mounted, flush with the bottom edge of the cut-out (there is no way to level the drawer once it has been installed, so make sure that the supports are level). The floor or runners must be capable of supporting at least 65 lbs.
- C** Cabinet surfaces must be an appearance finished surface for flush installation. Cleats may be visible and should be finished to match cabinetry.
- D** For optimal finished appearance, Wall Oven must use ZX30VT1 flush vent trim accessory.

For more details refer to the installation instructions for this product.

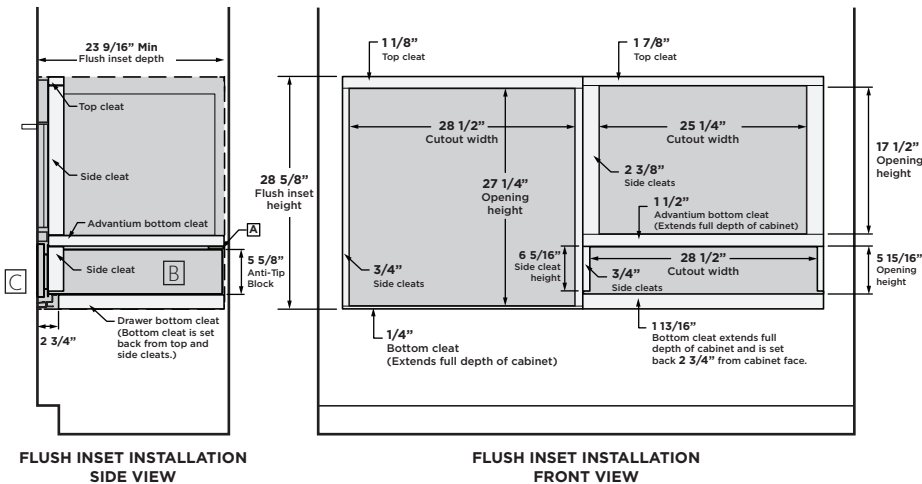

FLUSH INSET INSTALLATION  
SIDE VIEW

FLUSH INSET INSTALLATION  
FRONT VIEW

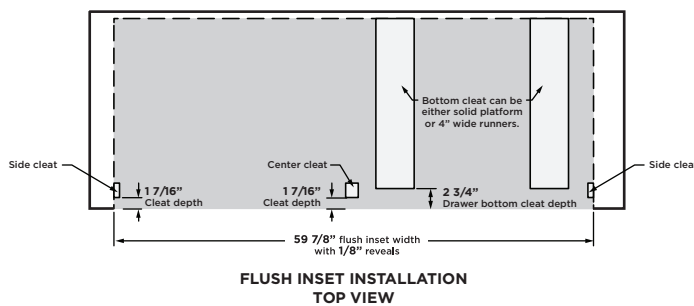

FLUSH INSET INSTALLATION  
TOP VIEW

## INSTALLATION UNDER STATEMENT WALL OVEN

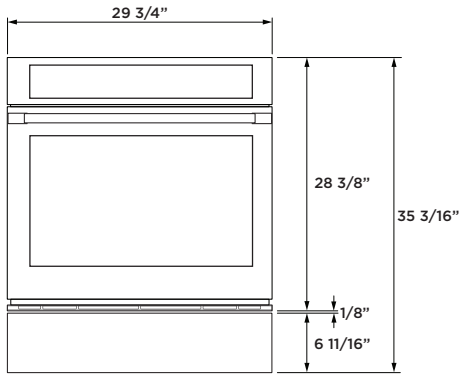

PRODUCT FRONT VIEW

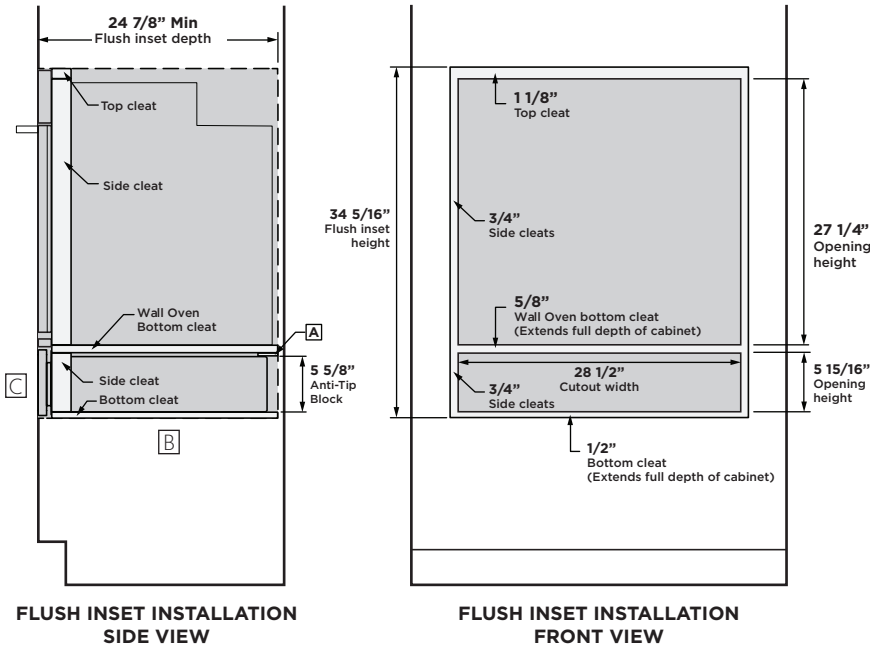

FLUSH INSET INSTALLATION  
SIDE VIEW

FLUSH INSET INSTALLATION  
FRONT VIEW

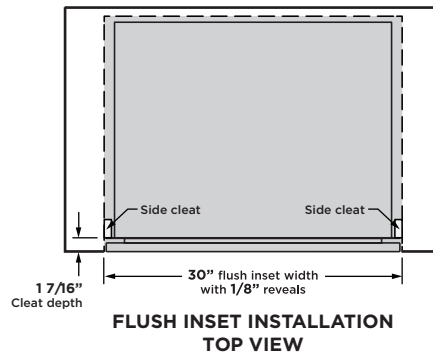

FLUSH INSET INSTALLATION  
TOP VIEW

## HELPFUL TIPS

- A** Install an anti-tip block against rear wall, 5 5/8" from floor of cutout to bottom of block. The anti-tip block must be installed to prevent the drawer from tipping forward when opened and loaded. Failure to add the anti-tip block could result in personal injury.
- B** The storage drawer may be supported by either a solid bottom or 2"x2" or 2"x4" runners. The support must be level and rigidly mounted, flush with the bottom edge of the cut-out (there is no way to level the drawer once it has been installed, so make sure that the supports are level). The floor or runners must be capable of supporting at least 65 lbs.
- C** Cabinet surfaces must be an appearance finished surface for flush installation. Cleats may be visible and should be finished to match cabinetry.

For more details refer to the installation instructions for this product.