



Subject to change

SPECIFICATIONS

Overall Width	29 9/16" (75.1 cm)
Overall Height	83 1/2" (212.1 cm)
Overall Depth	24 3/4" (62.9 cm)
Door Clearance at 90°	33 3/8" (84.8 cm)
Cutout Width	29 13/16" (75.7 cm)
Cutout Height	84" (213.4 cm)
Cutout Depth	25" (63.5 cm)
Plumbing Requirements	GE SmartConnect kit
Net Weight (approx)	510 lb (231.3 kg)

ATTENTION ELECTRICIAN:
 A 115 volt 60Hz., 15 or 20 amp power supply is required. An individual properly grounded branch circuit or circuit breaker is recommended. For multiple unit installation, each unit requires separate individually properly grounded circuit or breaker and separate properly grounded 3-prong electrical receptacle recessed.

WARNING:
 When installing appliance, you must use and follow the product installation instructions. These can be found with unit or on web at monogram.com.

OVERALL DIMENSIONS

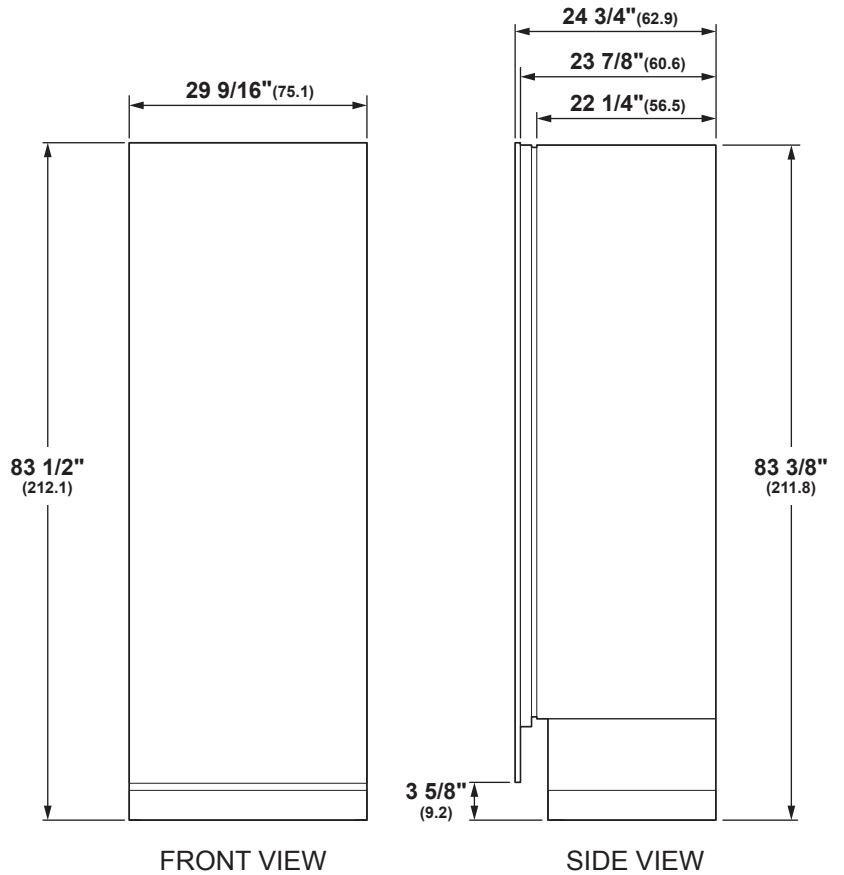

FRONT VIEW

SIDE VIEW

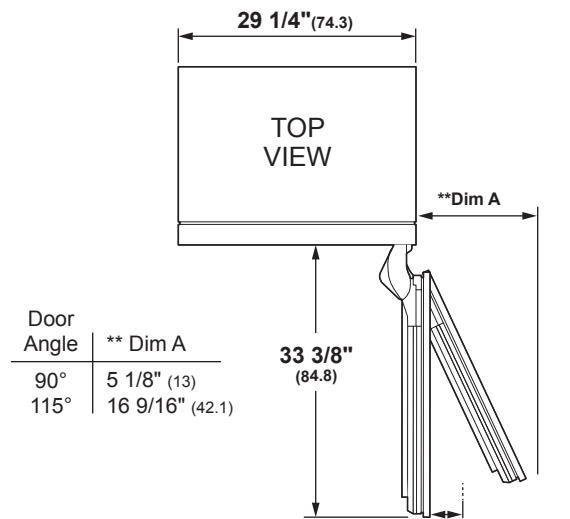

Door Angle	** Dim A
90°	5 1/8" (13)
115°	16 9/16" (42.1)

** Allow 4 9/16" (11.6) min clearance to a adjacent wall from cutout

** Dimensions based on handle height of 2 9/16" (6.5)

Dimensions in parentheses are in centimeters unless otherwise noted. Actual product dimensions may vary due to manufacturing tolerances.

ELEVATE EVERYTHING



SINGLE INSTALLATION

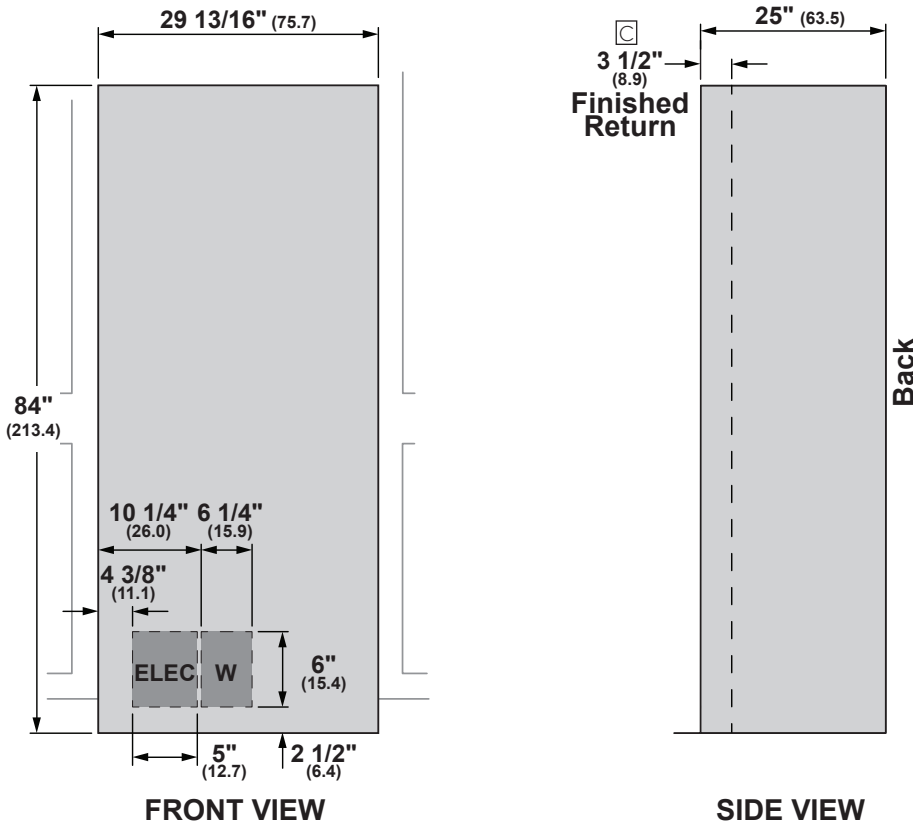

INTEGRATED INSTALLATION

⚠ WARNING:
When installing appliance, you must use and follow the product installation instructions. These can be found with unit or on web at monogram.com.
This document is intended for cabinet and panel construction only.

NOTES

- ☐ A minimum 3 1/2" (8.9) finished return matching cabinet exterior recommended on interior on all sides and top at front of opening

NOTES

Trimmed freezers are designed to be customized with decorative panels. Field-installed 3/4" custom door panels are required.

Maximum total panel weight:
• Door panel - 45 lbs.

Note: For panels constructed with rails and stiles (5-panel), the rails and stiles must be a minimum of 2" wide.

For Custom Panels: Use templates provided with units to pre-drill holes for mounting panel brackets (provided with unit). Adjustment screws and instructions also provided with units.

Requires custom handle from cabinet maker.

Stainless steel handle and panel options:

ZK1SN309NLH: Left-hand 30" stainless steel door panel

ZK1SN304NRH: Right-hand 30" stainless steel door panel

ZKSP1H1CN: Minimalist handle for stainless steel panels only

ZKSP1H1PN: Statement handle for stainless steel panels only

FLUSH 3/4" PANEL DIMENSIONS SINGLE INSTALLATION

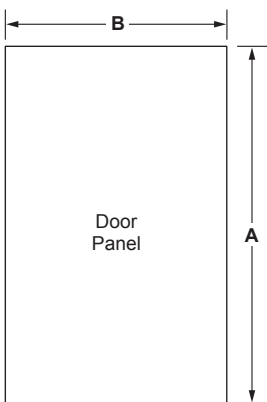

PANEL DIMENSIONS

A	B
79 7/8"	29 9/16"

ELEVATE EVERYTHING

MONOGRAM

DUAL INSTALLATION
30" INTEGRATED FREEZER, ZIF301NPNII AND
30" INTEGRATED REFRIGERATOR, ZIR301NPNII

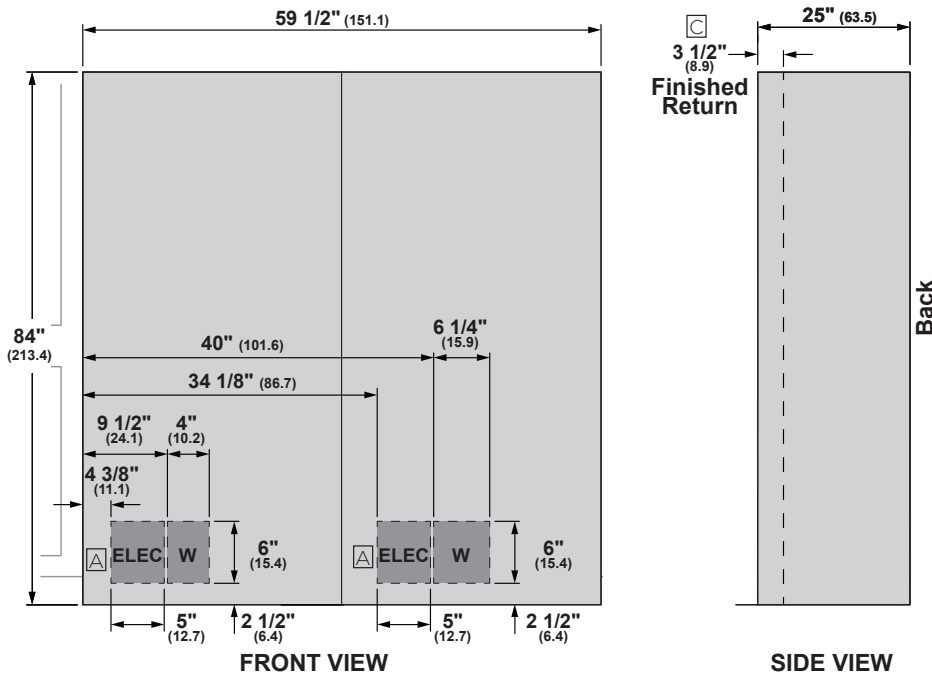

INTEGRATED
INSTALLATION

NOTES

- Ⓐ A separate 115V, 60Hz, 15- or 20-amp power supply is recommended for each product.
- Ⓑ Cutout based on installation of two products with a left-and-right-hand door swing.
- Ⓒ A minimum 3 1/2" (8.9) finished return matching cabinet exterior recommended on interior on all sides and top at front of opening

DUAL INSTALLATION
30" INTEGRATED FREEZER, ZIF301NPNII AND
24" INTEGRATED REFRIGERATOR, ZIR241NPNII

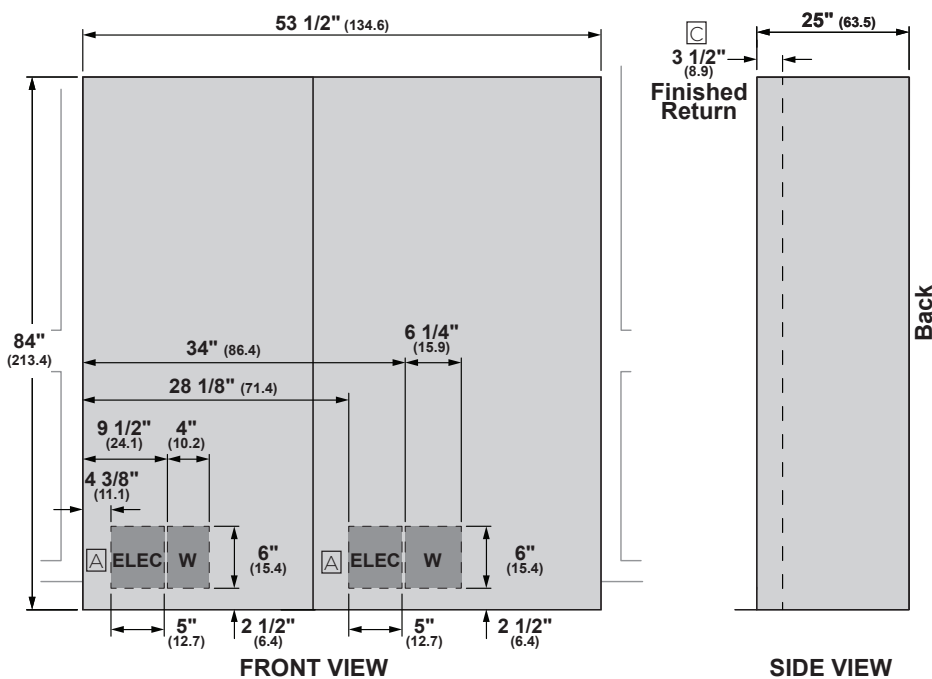

ELEVATE EVERYTHING™



FLUSH 3/4" PANEL DIMENSIONS DUAL INSTALLATION WITH 30" FREEZER, ZIF301NPNII AND 30" REFRIGERATOR, ZIR301NPNII

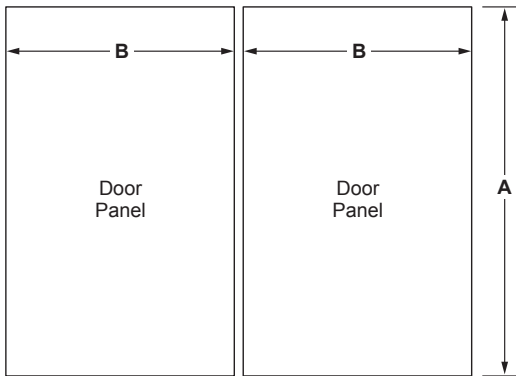

PANEL DIMENSIONS

A	B
79 7/8"	29 9/16"

FLUSH 3/4" PANEL DIMENSIONS DUAL INSTALLATION WITH 30" FREEZER, ZIF301NPNII AND 24" REFRIGERATOR, ZIR241NPNII

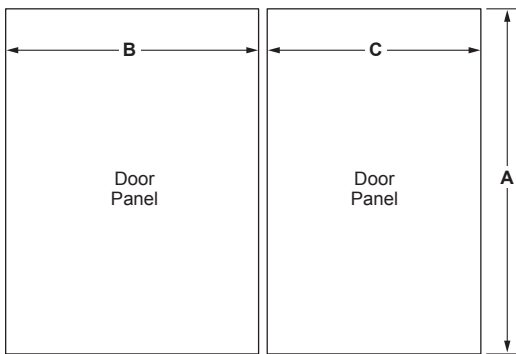

PANEL DIMENSIONS

A	B	C
79 7/8"	29 9/16"	23 9/16"

INTEGRATED INSTALLATION

NOTES

Trimmed freezers are designed to be customized with decorative panels. Field-installed 3/4" custom door panels are required.

Maximum total panel weight: 45 lbs

Note: For panels constructed with rails and stiles (5-panel), the rails and stiles must be a minimum of 2" wide.

For Custom Panels: Use templates provided with units to pre-drill holes for mounting panel brackets (provided with unit). Adjustment screws and instructions also provided with units.

Requires custom handle from cabinet maker.

Stainless steel handle and panel options:

ZK1SN249NLH: Left-hand 24" stainless steel door panel

ZK1SN244NRH: Right-hand 24" stainless steel door panel

ZK1SN309NLH: Left-hand 30" stainless steel door panel

ZK1SN304NRH: Right-hand 30" stainless steel door panel

ZKSP1H1CN: Minimalist handle for stainless steel panels only

ZKSP1H1PN: Statement handle for stainless steel panels only

Dual installation full width toekick options:

ZKK54P: 54" stainless toekick

ZKK60P: 60" stainless toekick

DUAL PRODUCT CLEARANCES

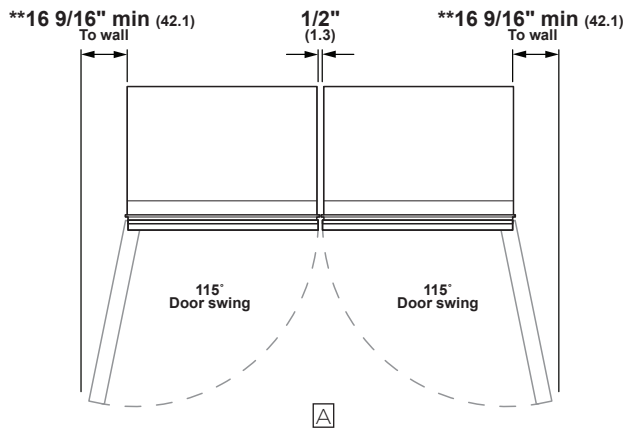

** Dimensions based on handle height of 2 9/16" (6.5)

INTEGRATED
INSTALLATION

NOTES

- Ⓐ In a side-by-side installation of a left-and-right-hand door swing product, 1/2" clearance between the units is required. Also required is Side-by-Side Heater/ Dual Installation Kit, ZKUN

ELEVATE EVERYTHING

MONOGRAM

FEATURES AND BENEFITS

FULLY INTEGRATED COLUMN DESIGN

With concealed hinge offers a look of seamless perfection that installs flush with surrounding cabinetry

PANEL-READY EXTERIOR WITH SIX-WAY ADJUSTABILITY

Accepts Statement or Minimalist Collection stainless steel panels ordered separately from Monogram or custom panel & handle from your cabinet maker

RETROFIT CAPABILITY

Allows you to replace a 48" or 42" built-in side-by-side refrigerator with two column refrigerators with no cabinet or electrical modifications

FINELY CRAFTED, ADJUSTABLE ALUMINUM DOOR BINS WITH GLASS ACCENTS

Offer easy access to quick-grab items

ADJUSTABLE, HYDROPHOBIC, SPILL-RESISTANT GLASS SHELVES WITH INTEGRATED LED LIGHTING

Provide convenient storage and a clean appearance

REMOTE CONNECTIVITY VIA WIFI

Allows you to wirelessly control freezer settings from your smartphone, using an available app

REMOVABLE ICE STORAGE AND MULTIPLE SLIDE-OUT BINS

Provide added convenience

WATER FILTRATION SYSTEM

Supplies you with clean, fresh-tasting ice cubes

UPFRONT, ELECTRONIC-TOUCH CONTROLS

Make it easy to adjust climate settings to create ideal food storage conditions

RAMP-UP LED INTERIOR LIGHTING

Throughout the freezer compartment accentuates the sophisticated interior and allows easy viewing of contents

DEDICATED EVAPORATOR SEALED SYSTEM

Helps maintain a precise temperature throughout the freezer compartment

SABBATH MODE

Designed to disable functions in accordance with Sabbath-observing practices



Subject to change

ELEVATE EVERYTHING™

MONOGRAM