

FEC60B-2
24" Electric Freestanding Range

Porter & Charles

FEC60B-2

24" Electric Freestanding Range



COOK TOP FEATURES

- 4 x Hi-Lite Zones
 - 2 x 145mm Hi-lite elements – 1, 200 Watts
 - 1 x 180mm Hi-lite element – 1, 800 Watts
 - 1 x 210mm Hi-lite element – 2, 200 Watts

RANGE FEATURES

- 24" (60cm) stainless steel slide-in electric range
- 63L(2.22cu.ft)oven capacity
- 8 cooking functions including True Fan convection
- ThermiC° hot air cooking technology for perfect cooking
- Plus triple glazed door
- 4 electric burners, 2 expandable
- Residual heat indicator
- Diamond glazed interior
- Catalytic low temperature self cleaning liners
- Fully programmable clock/timer with delay start and finish

OVEN FEATURES

- 63L(2.22cu.ft)oven capacity
- Defrost
- Conventional Oven Cooking
- Fan Assist Cooking
- High Bake Cooking
- TrueFan Convection Cooking
- Fan Assist Grill
- Full Grill
- Half Grill
- Pizza mode

Specifications

FEC60B-2

RANGE DIMENSIONS

- D: $22\frac{5}{8}''$ x H: $33\frac{7}{8}'' - 36\frac{1}{4}''$ x W: $23\frac{5}{8}''$
- D: 640 mm x H: 860 mm - 920 mm x W: 600 mm

CUT-OUT DIMENSIONS

- H: $24\frac{3}{16}''$ x W: $23\frac{11}{16}''$
- H: min $33\frac{7}{8}''$ x W: 602

ELECTRICAL REQUIREMENTS

- 208 / 240 Volt 60Hz
- PORTER&CHARLES Ranges are supplied with 40 AMP corded plug

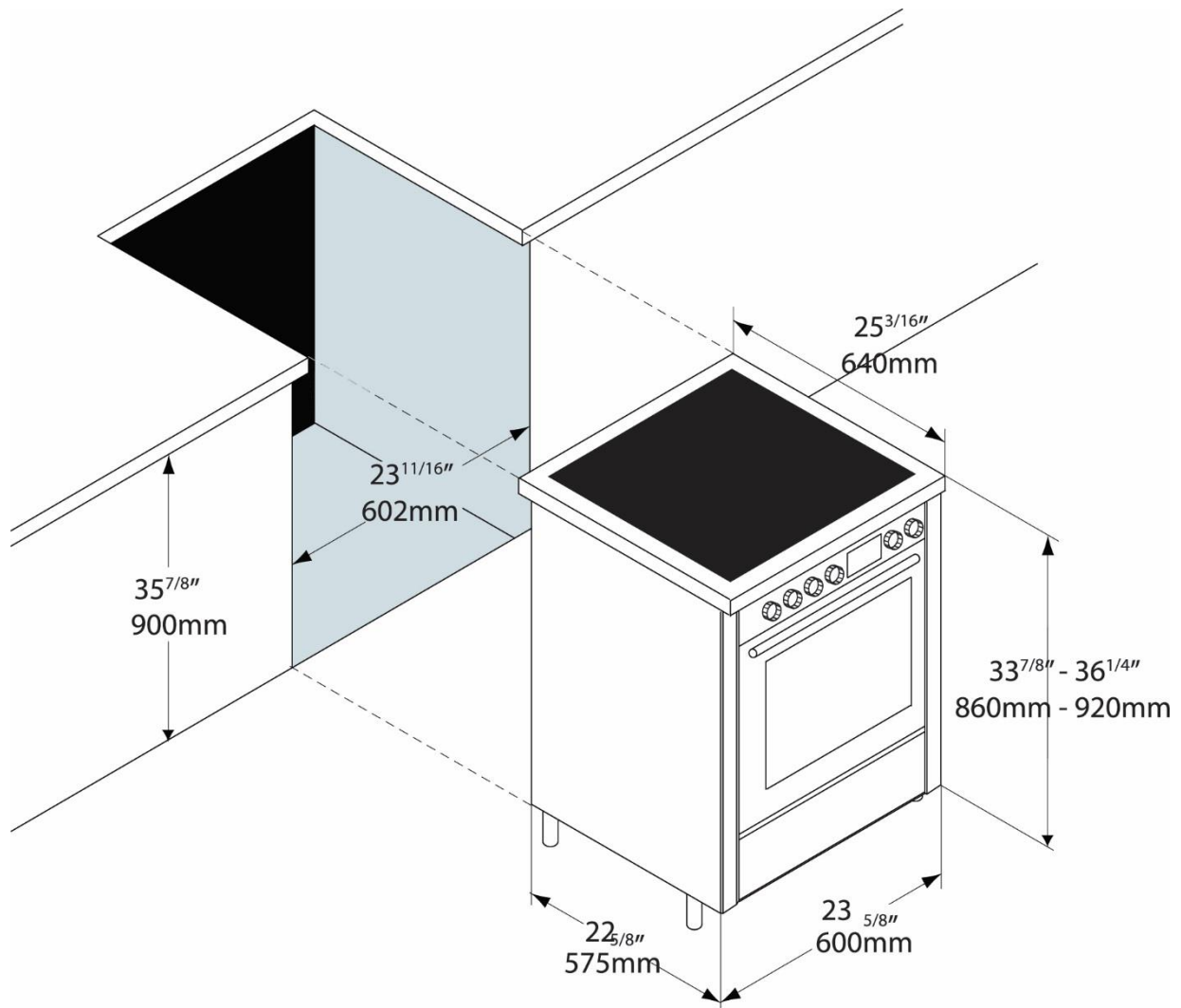

Specifications are subject to change without notice.

Detailed Specification Available at www.porterandcharles.ca

Porter&Charles products are designed and built to the highest standards.
Each appliance is covered by a comprehensive 2 year parts and labour warranty.

Refer to product warranty policy for complete terms and conditions.

For Service & Parts
EURO-PARTS

39822 Belgrave Rd,
Belgrave, Ontario, Canada,
N0G 1E0
1.800.678.8352

Porter&Charles appliances are imported and distributed in North America by Euro-Line Appliances Inc.
For more information visit
www.euro-line-appliances.com / www.elawest.com

EURO-LINE APPLIANCES INC.

871 Cranberry Court
Oakville, ON L6L 6J7
Canada
Toll Free: 1-800-421-6332
Showroom: 905-829-3980
marketing@euro-line-appliances.com

EURO-LINE APPLIANCES WEST INC.

2912 West 4th Ave
Vancouver, BC V6K 1R2
Canada
Toll Free: 1-855-352-9378
Showroom: 604-235-3980
info@elawest.com