

NX58H5650WS

5.8 cu. ft. Freestanding Gas Range with True Convection

Features

- 5 Gas Burners
 - Right Front: Dual 18K BTU
 - Left Front: 15K BTU
 - Right Rear: 5K BTU
 - Left Rear: 9.5K BTU
 - Center: 9.5K BTU (Oval)
- Large Oven Capacity – 5.8 cu. ft.
- Cast Iron 3 Piece Grates
- Griddle and Wok Grate
- True Convection Oven
- Warming Drawer (3 Levels)
- Grate Indicator Marks

Convenience

- Auto Oven Light
- Proofing
- Sabbath Mode
- Delay Start
- Auto Shut-Off Option
- Child Safety Lock
- Self Clean
- 4 Easy Cook Presets
- 3 Chrome Oven Racks, including 1 Gliding Rack



Five Burners



True Convection

Available Color



Stainless Steel

Signature Features

FLEXIBLE COOKTOP WITH TRUE DUAL POWER BURNER

- Whether you're boiling water, melting chocolate, or simmering sauce, there's a burner for your needs: a dual power burner with 18,000 BTU, plus simmer, oval, and regular burners.

TRUE CONVECTION

- Heated fan system is great for baking and broiling because temperature is distributed thoroughly and food cooks evenly.

GRIDDLE AND WOK GRATE

- Cook a variety of breakfast foods or grilled sandwiches at once on the removable stovetop griddle.
- Accommodates a round-bottom wok on the custom-made wok grate.

LARGE CAPACITY

- Our extra-spacious 5.8 cu. ft. large-capacity oven easily handles turkey roasters and large baking sheets.

GRATE INDICATOR MARKS

- Indicator marks located on the grates allow cookware to be ideally placed for precise cooking.

SAMSUNG

NX58H5650WS

5.8 cu. ft. Freestanding Gas Range with True Convection

Installing Your Range

*30" minimum clearance between the top of the cooking surface and the bottom of an unprotected wood or metal cabinet; or 24" minimum when the bottom of the wood or metal cabinet is protected by not less than 1/4" flame retardant millboard covered with not less than no.28 MSG sheet steel, 0.015" stainless steel, 0.024" aluminum or 0.020" copper.

**15" minimum between the countertop and the adjacent cabinet bottom.

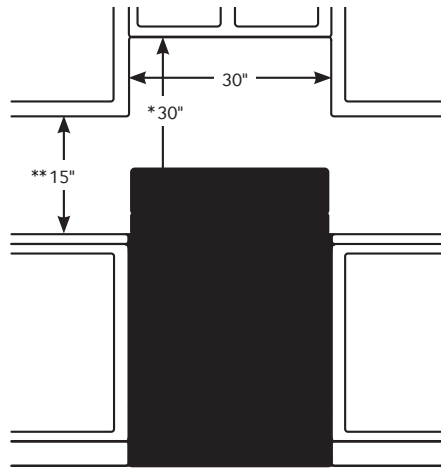

IMPORTANT: To eliminate the risk of burns or fire caused by reaching over heated surface units, cabinet storage space located above the surface units should be avoided. If cabinet storage is to be provided, the risk can be reduced by installing a range hood that projects horizontally a minimum of 5" beyond the bottom of the cabinets.

Dimensions

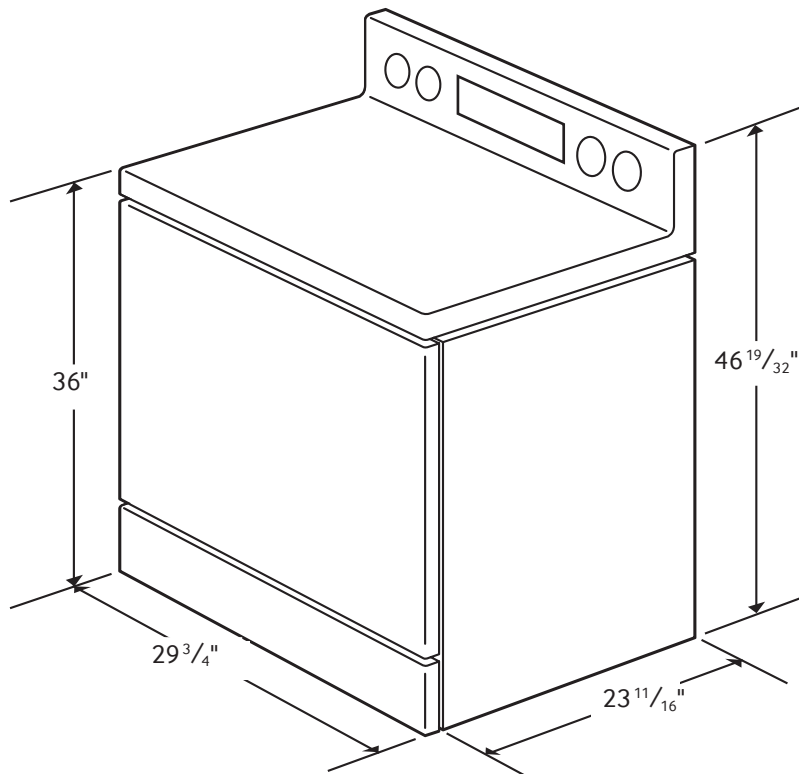

Total Power (BTU)

57,000 BTU

Power Source

120 V/60 Hz

Black Enamel 5 Burner Cooktop

- Right Front: 18000 BTU – Dual
- Left Front: 15000 BTU
- Right Rear: 5000 BTU
- Left Rear: 9500 BTU
- Center Rear: 9500 BTU – Oval

Oven

- Bake: 150°F - 550°F
- Convection Bake: 150°F - 550°F
- Bake Burner: 18000 BTU
- Broil Burner: 13500 BTU
- Variable Broil: Low/Hi (375°F - 480°F)
- Convection Roast: 150°F - 550°F
- Proofing
- Sabbath Mode

Warming Drawer

- Capacity: 0.7 cu. ft.
- Heating Performance: 600 W (4 pass)
- Temperature Settings: High, Medium, Low

Warranty

One (1) Year All Parts and Labor
Five (5) Years Gas Cooktop

Product Dimensions & Weight (WxHxD)

Actual Oven Dimensions:

25" x 19" x 21 1/8"

Outside Net Dimensions:

29 3/4" x 46 19/32" x 23 11/16"

Weight: 207 lbs.

Shipping Dimensions & Weight (WxHxD)

Dimensions:

32 7/8" x 50 9/16" x 30 1/8"

Weight: 233 lbs.

Color

Stainless Steel

Model #

NX58H5650WS

UPC Code

887276674360

Actual color may vary. Design, specifications, and color availability are subject to change without notice. Non-metric weights and measurements are approximate.

©2013 Samsung Electronics America, Inc. 85 Challenger Road, Ridgefield Park, NJ 07660. Tel: 800-SAMSUNG. samsung.com. Samsung is a registered trademark of Samsung Electronics Co. Ltd.

SAMSUNG