

MS19M8000AS

SAMSUNG

1.9 cu. ft., Countertop Microwave and Trim Kit
for Built-in Applications in Stainless Steel Finish



Signature Features

1.9 cu. ft. Capacity

- Accommodates a variety of dishes so you can prep large meals quickly.

Sensor Cook



- Automatically adjusts cooking time for optimal results.

Ceramic Enamel Interior

- Makes removing grease or oil effortless and protects against scratches from daily use.



Available Colours

-  Stainless Steel
-  Black Stainless Steel



Sensor Cook



Ceramic Enamel Interior

Features

- Eco Mode
- Cooking Presets
- 900W of Cooking Power
- 10 Power Levels
- Auto Defrost
- LED Display
- 30" Matching Trim Kit (see next page for details.)

Convenience

- Kitchen Timer
- Clock (12hr/24hr) with Daylight Saving Time Adjustment
- Child Safety Lock
- Reminder End Signal

MS19M8000AS

SAMSUNG

1.9 cu. ft., Countertop Microwave and Trim Kit for Built-in Applications in Stainless Steel Finish

Dimensions

Microwave

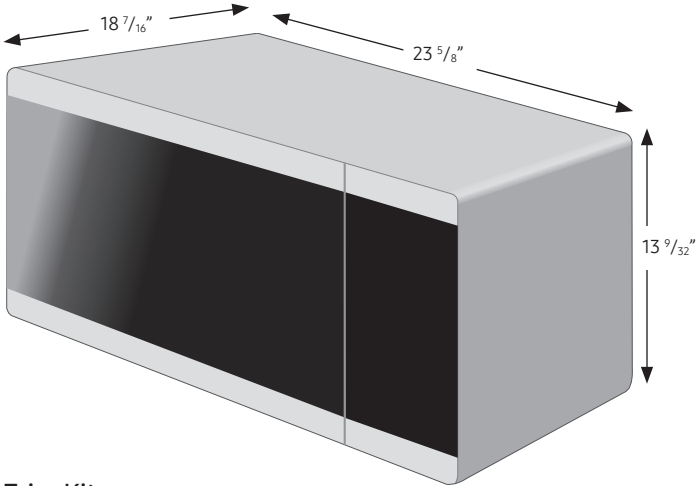

Trim Kit

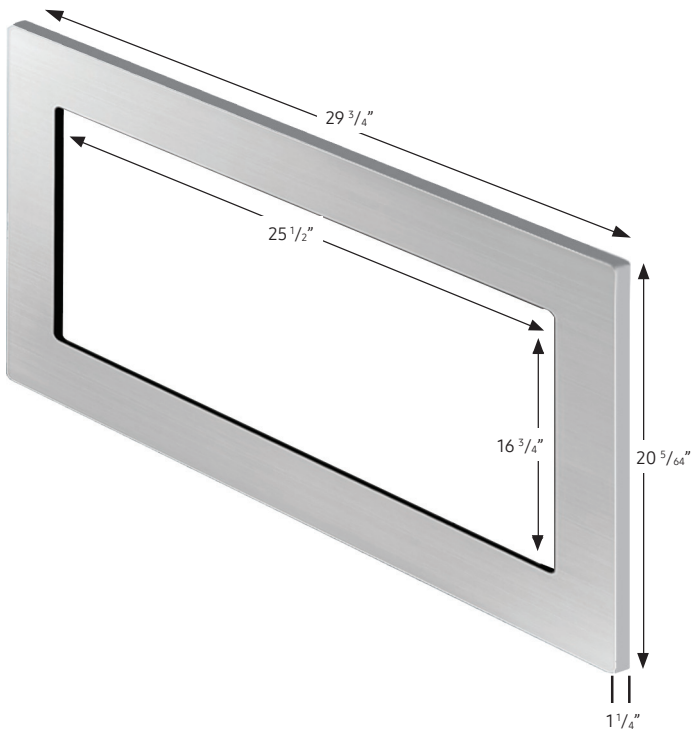

Specifications

- Oven Cavity: 1.9 cu. ft.
- Power Output: 900W
- Power Consumption: 1600W/13.3 A
- Power Source: 120V / 60 Hz
- Control Method: Electronic Touch
- Display: LED (Ice Blue)
- Cooking Control: 10 Power Levels Including Defrost
- Cooking Timer: Digital, up to 99 Minutes, 99 Seconds
- Microwave Distribution System: Turntable

Warranty

One (1) Year Parts and Labour
Five (5) Years on Magnetron Microwave Technology

Microwave Product Dimensions & Weight (WxHxD)

Outside Dimensions: 23 5/8" x 13 9/32" x 18 7/16"
Interior Cavity Dimensions: 17 3/8" x 10 5/8" x 17 13/16"
Weight: 43.03 lbs. (19.5 Kg)

Trim Kit Dimensions (WxHxD)

Outside Dimensions: 29 3/4" x 20 5/64" x 1 1/4"
Cut Out (WxH): 25 1/2" x 16 3/4"
Weight: 12.83 lbs. (5.81 Kg)

Microwave Shipping Dimensions & Weight (WxHxD)

Dimensions: 26 1/4" x 16 13/32" x 20 1/4"
Weight: 47.97 lbs. (27.75 Kg)

Trim Kit Shipping Dimensions (WxHxD)

Dimensions: 22 3/4" x 6 3/4" x 33 5/32"
Weight: 16.78 lbs. (7.6 Kg)

Countertop Microwave and Trim Kit for Built-in Applications

For installation with Wall Ovens, respective codes must be paired together:

Colour:	Product:	Model #:	UPC Code:
Stainless Steel	Microwave	MS19M8000AS	887276263045
Stainless Steel	Trim Kit	MA-TK8020TS	887276263038
Black Stainless Steel	Microwave	MS19M8020TG	887276263052
Black Stainless Steel	Trim Kit	MA-TK8020TG	887276263021