

NE58M9430SS

SAMSUNG

Samsung Slide-In Electric Range

5.8 cu. ft. Capacity



Signature Features

Dual Convection

- Faster and more even cooking.
- Two fans circulate air throughout the oven.

Slide-in design

- Blends seamlessly with your kitchen for a modern and built-in look.
- Creates a high-end look without having to remodel.

Flexible Cooktop

- Flexible 5 element cooktop with 2 double elements accommodates multiple pan sizes.
- 12"/9" and 9"/6" double elements allow for optimal placement and flexibility for various pots and pans.

Available Colours



Stainless Steel



Dual Convection



Flexible Cooktop

Features

- True Dual Convection
- Slide-In Design
- Flexible Cooktop – 5 Electric Elements
 - Two Dual Burners (9"/12", 6"/9")
 - Two Single Burners (6")
 - Warming Center (7")
- Glass-Touch Controls
- Large Oven Capacity: 5.8 cu. ft.
- Wide View Door
- Storage Drawer
- Hidden Bake Element
- Sabbath Mode

Convenience

- Self + Steam Clean
- Hot Surface Indicator Lights
- Auto Oven Light
- Proofing
- Kitchen Timer
- Delay Start
- Auto Shut-Off Option
- Child Safety Lock
- 3 Preset Easy Cook Options

NE58M9430SS

SAMSUNG

Samsung Slide-In Electric Range

5.8 cu. ft. Capacity

Installation Specifications

30" minimum clearance between the top of the cooking surface and the bottom of an unprotected wood or metal cabinet; or 24" minimum when the bottom of the wood or metal cabinet is protected by not less than 1/4" flame-retardant millboard covered with not less than no.28 MSG sheet steel, 0.015" stainless steel, 0.024" aluminum or 0.020" copper.

** 18" minimum between the countertop and the adjacent cabinet bottom.

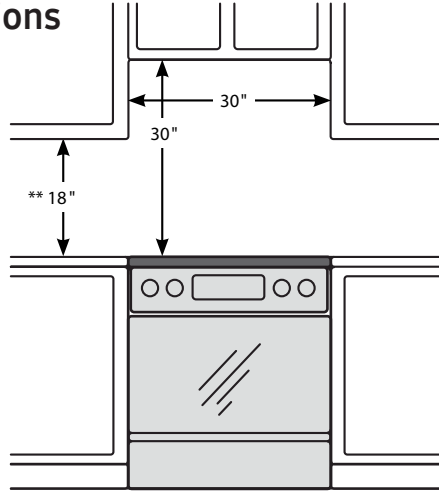

IMPORTANT: To eliminate the risk of burns or fire caused by reaching over heated surface units, cabinet storage space located above the surface units should be avoided. If cabinet storage is to be provided, the risk can be reduced by installing a range hood that projects horizontally a minimum of 5" beyond the bottom of the cabinets.

Dimensions

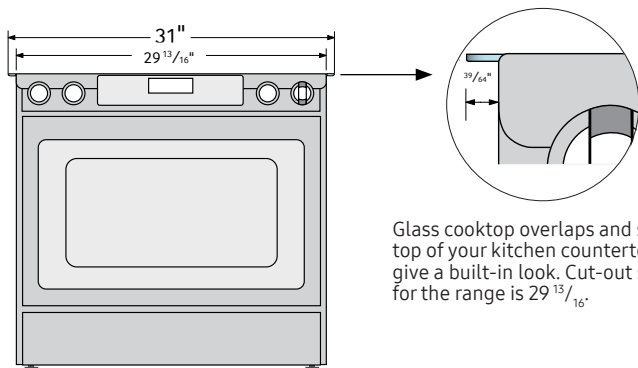

Glass cooktop overlaps and sits on top of your kitchen countertop to give a built-in look. Cut-out space for the range is 29¹³/₁₆".

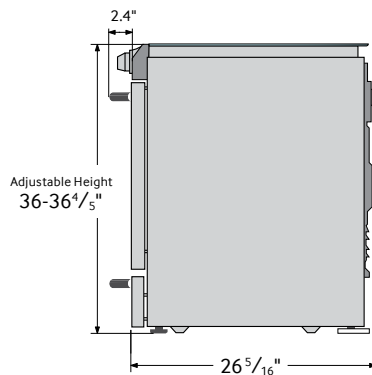

Electric Ceramic Cooktop

- Right Front: 9/12", 3.0kW
- Left Front: 6/9", 3.0kW
- Right Rear: 6", 1.2kW
- Left Rear: 6", 1.2kW
- Warm Center: 100W

Oven

- Hidden Bake Element: 3000W
- Bake: 175°F - 550°F
- Convection Bake: 175°F - 550°F
- Convection Roast: 175°F - 550°F
- Broil (Low - High)
- Convection Element/Heater: 1250W
- Proofing
- Sabbath Mode
- Storage Drawer Capacity - 0.7 cu. ft.

Warranty

One (1) Year All Parts and Labour

Product Dimensions & Weight (WxHxD)

Outside Net Dimensions:

31" x 36-37 1/8" (Adjustable) x 26 5/16"

Weight: 191.6 lbs.

Shipping Dimensions & Weight (WxHxD)

Dimensions: 33 1/16" x 41 3/4" x 30 5/16"

Weight: 215.8 lbs.

Colour

Stainless Steel

Model

NE58M9430SS

UPC Code

88727199191