

RB15DG6000SRAA

SAMSUNG

15 cu. ft. Counter-depth Bottom-Mount Refrigerator



Available Colour



Stainless Steel Finish

Signature Features

All-Around Cooling

An All-Around Cooling system cools the entire fridge evenly from corner to corner. It continually checks the temperature and circulates cool air through strategically placed vents.

SmartThings Connectivity

Monitor and manage the refrigerator's performance from your smartphone using its embedded WiFi and SmartThings App*.

* Available on Android and iOS devices. A Wi-Fi connection and a Samsung account are required.

Energy Star® Certified

Eco-friendly and energy-efficient.

Digital Inverter Compressor

Automatically adjusts its speed in response to cooling demand across 7 levels. As a result, it's much quieter and uses up to 50% less power.



SmartThings Connectivity



Digital Inverter Compressor

Features

- 4 Shelves
- Counter-Depth
- Crisper
- 5 Door Bins
- High Efficiency LED Lighting
- Sabbath Mode

Convenience

- CoolTight Door
- Door Alarm
- All-Around Cooling
- Temperature Control
- Power Cool & Power Freeze
- Wi-Fi Embedded
- Reversible Door
- Twist Ice Maker



ENERGY STAR® rated:
420 kWh/yr



RB15DG6000SRAA

SAMSUNG

15 cu. ft. Counter-depth Bottom-Mount Refrigerator

Installation Specifications

1. Measure the height, width and depth of the opening, making sure to include baseboards, molding tile, countertop overhang, etc. Check to be sure there is enough room to open the door (consider walls, islands or other obstacles when measuring).
2. Refer to illustration below to determine dimensions.
3. Allow $1\frac{3}{4}$ " of clearance on hinge side of refrigerator when installing next to a wall.
4. Allow 2" minimum clearance at rear for proper air circulation and water/electrical connections. More than 1" recommended for clearance at sides and top for ease of installation.
5. Ensure each door and entryway in the home is wide enough for the refrigerator to be moved through easily.

For optimal usage and ability to open refrigerator doors completely, do not install next to a wall.

Please note: The following dimensions and cutout information is for planning purposes only. For complete installation details, consult manual packed with product or download manual online at samsung.com.

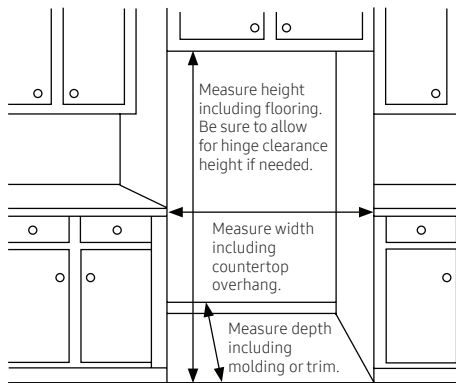

Dimensions

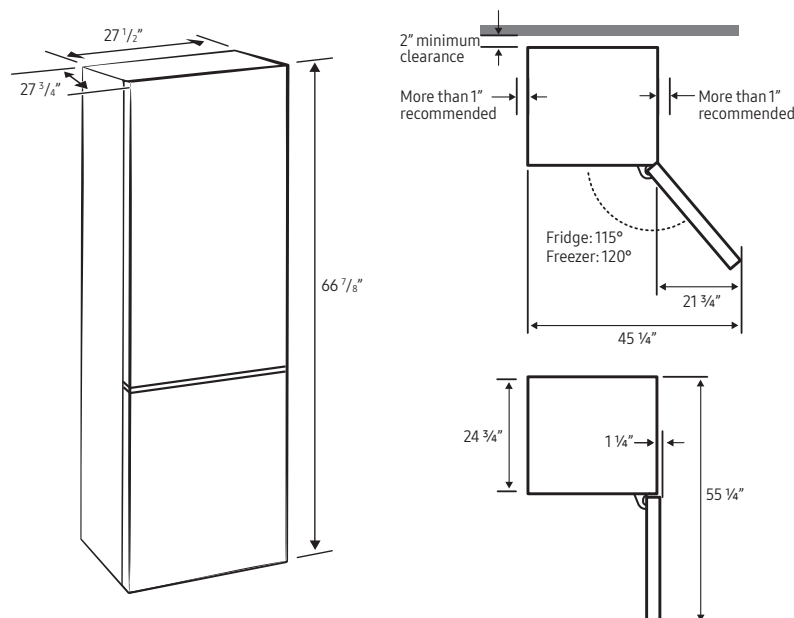

Total Capacity: 15 cu. ft.

Refrigerator: 10.6 cu. ft.

- 1 Humidity-Controlled Crisper
- 4 Tempered Glass Spill-Proof Shelves
- 5 Door Bins
- High Efficiency LED Lighting

Freezer: 4.4 cu. ft.

- 3 Drawer Dividers
- High Efficiency LED Lighting
- Twist Ice Maker

Consumption Rate	420 kWh/year
Volt/Amps	115V / 60Hz / 3.0A
Power Cord Length	2 Meters

Warranty

One (1) Year Parts and Labour on Refrigerator
Ten (10) Years Parts on Digital Inverter Compressor

Product Dimensions & Weight (WxHxD)

Net Dimensions (WxHxD with hinges, handles and doors):

27 1/2" x 66 7/8" x 27 3/4"

Dimensions (WxHxD without hinges and door):

27 1/2" x 65 5/8" x 27 3/4"

Net Weight: 158.75 lb (72 kg)

Shipping Dimensions & Weight (WxHxD)

Dimensions: 30 9/32" x 70 55/64" x 29 9/64"

Shipping Weight: 172 lb (78 kg)

Colour

Stainless Look

Model #

RB15DG6000SRAA

UPC

887276881409

Effective September 2024