

# REFRIGERATOR

MODEL : SJB1257HSC



Refrigerator: Model SJB1257HSC

CONSUMER LIMITED WARRANTY.....	3	USER INTERFACE .....	12
IMPORTANT SAFETY INSTRUCTIONS.....	4	DAILY USE.....	13
INSTALLATION INSTRUCTIONS.....	7	CARE AND CLEANING.....	15
APPEARANCE OVERVIEW.....	11	TROUBLE SHOOTING .....	16

# CUSTOMER ASSISTANCE

CANADA ONLY

To aid in answering questions if you call for service or for reporting loss or theft, please use the space below to record the model and serial number located on the back side of the unit.

Model Number: \_\_\_\_\_

Serial Number: \_\_\_\_\_

Date of Purchase: \_\_\_\_\_

Dealer Name: \_\_\_\_\_

Address: \_\_\_\_\_

City: \_\_\_\_\_

Province: \_\_\_\_\_

Postal Code: \_\_\_\_\_

Telephone: \_\_\_\_\_

## PRODUCT SUPPORT

If you have questions about the setup or operation of your product, please refer to the corresponding section within this manual.

Additionally, visit [www.sharp.ca](http://www.sharp.ca) to access exclusive content about your product including:

- Find a Dealer
- Find Service Locations
- Downloads including the Installation Guide, Spec Sheet, and Owner's Manual

## CONTACT US

If at any time you have questions or comments concerning your SHARP product, please contact the SHARP Customer Assistance Center. We are available to assist you through multiple contact methods for your convenience:



### EMAIL

Available 24/7

See the Contact Us section on our site.

[rpdesk@sharpsec.com](mailto:rpdesk@sharpsec.com)



### SUPPORT SITE

Product Downloads, Service Locator, Where to Buy, Toner Recycling Program and more.

CA | [www.sharp.ca](http://www.sharp.ca)



### CALL US

CA 866-437-4277  
Mon-Fri: 8am-5pm EST  
(except statutory holidays)

Contact a Sharp Advisor on the phone

# SHARP.

## CANADA CONSUMER LIMITED WARRANTY

### Congratulations on your purchase!

Sharp Electronics of Canada Ltd. ("Sharp") warrants to the first purchaser for this Sharp brand product ("Product"), when shipped in its original container and sold or distributed in Canada by Sharp or by an authorized Sharp dealer, and Product was not sold "as is" or "sales final" that the Product will during the applicable warranty period, be free from defects in material and workmanship, and will within the applicable warranty period, either repair the defective Product or provide the first purchaser a replacement of the defective Product.

This warranty does not apply to any appearance items of the product nor to the additional excluded item(s) set forth below nor to any product the exterior of which has been damaged or defaced, which has been subjected to improper voltage or other misuse, abnormal service or handling, which has been altered or modified in design or construction, or if the serial number or model number affixed to Product has been removed, defaced, changed, altered or tampered with.

How to get service: Should this Sharp product fail to operate during the warranty period, warranty service is provided by an Authorized Sharp Service Centre or an Authorized Sharp Servicing Dealer. In home warranty service will be carried out to locations accessible by on-road service vehicle and within 50 km of an authorized Sharp service centre. The servicer may if necessary take the unit for repair at the servicer's facility. No other person (including any Sharp dealer or service centre) is authorized to extend, enlarge or transfer this warranty on behalf of Sharp.

The express warranties in this limited warranty are, except for consumer purchasers domiciled in Quebec, in lieu of and, except to the extent prohibited by applicable law, Sharp disclaims all other warranties and conditions, express or implied, whether arising by law, statute, by course of dealing or usage of trade, including, without limitation, implied warranties or conditions of merchantability and/or quality, fitness for a particular use or purpose, and/or non-infringement. Limitations (not applicable to consumer purchasers domiciled in Quebec to the extent prohibited under Quebec law): (a) Sharp shall not be liable for any incidental, special, consequential, economic, exemplary or indirect damages of any kind or nature (including lost profits or damages for loss of time or loss of use or loss of data) arising from or in any connection with the use or performance of a Product or a failure of a Product, even if Sharp is aware of or has been advised of the possibility of such damages; (b) the remedies described in this limited warranty constitute complete fulfillment of all obligations and responsibilities of Sharp to the purchaser with respect to the Product and shall constitute full satisfaction of all claims, whether based on contract, negligence, strict liability or otherwise. Some provinces may not allow the exclusion or limitation of certain damages, or limits on the duration or voiding of implied warranties or conditions; in such provinces, the exclusions and limits herein may not apply. This limited warranty is, except for consumer purchasers domiciled in Quebec, governed by the laws of the Province in Canada in which the purchaser has purchased the Product. For consumer purchasers domiciled in Quebec this limited warranty is governed by the laws of Quebec.

**Your product model number & description**      SJB1257HSC, Refrigerator/Freezer

**Warranty period for this product:**      One (1) year parts and labor, including in-home service.  
Five (5) years Parts ONLY, for sealed system (condenser, dryer, connecting tube and evaporator) and compressor.

**Additional item(s) excluded from warranty coverage (if any):**

- Commercial, non-residential, or use inconsistent with published installation and product operational instructions.
- Light bulbs.
- Any food or medicine loss due to refrigerator or freezer product failures.
- In home instruction on how to use your product.

**To obtain the name and address of the nearest Authorized Sharp Service Centre or Dealer, please contact:**

SHARP ELECTRONICS OF CANADA LTD  
335 Britannia Road East  
Mississauga, Ontario L4Z 1W9  
1-866-437-4277  
Website: [www.sharp.ca](http://www.sharp.ca)

---

SAVE THE PROOF OF PURCHASE AS IT IS NEEDED SHOULD YOUR APPLIANCE EVER REQUIRE WARRANTY SERVICE.

**THIS LIMITED WARRANTY IS VALID ONLY IN CANADA**

# IMPORTANT SAFETY INSTRUCTIONS

## MEANING OF SAFETY WARNING SYMBOLS

<b>⊘ PROHIBIT</b>
This is a prohibition symbol. Any in compliance with instructions marked with this symbol may result in damage to the product or endanger the personal safety of the user.
<b>⚠ WARNING</b>
This is a warning symbol. It is required to operate in strict observance of instructions marked with this symbol; or otherwise damage to the product or personal injury may be caused.
<b>⚠ CAUTION</b>
This is a cautioning symbol. Instructions marked with this symbol require special caution. Insufficient caution may result in slight or moderate injury, or damage to the product.
State of California Proposition 65 Warnings: WARNING: This product contains one or more chemicals known to the State of California to cause cancer. WARNING: This product contains one or more chemicals known to the State of California to cause birth defects or other reproductive harm.

## SAFETY WARNINGS

	<b>⚠ WARNING</b> <b>RISK OF FIRE/FLAMMABLE MATERIALS</b>
---	---

- This appliance is intended to be used in household and similar applications such as staff kitchen areas in shops, offices and other working environments; farm houses and by clients in hotels, motels and other residential type environments; bed and breakfast type environments; catering and similar non-retail applications.
- This appliance is not intended for use by persons (including children) with reduced physical, sensory or capabilities, or lack of experience and knowledge, unless they been given supervision or instruction concerning use of the appliance by a person responsible for their safety. Children should be supervised to ensure that they do not play with the appliance.
- If the supply cord is damaged, it must be replaced by the manufacturer, its service agent or similarly qualified persons in order to avoid a hazard.
- Do not store explosive substances such as aerosol cans with flammable propellant in this appliance.
- The appliance has to be unplugged after use and before carrying out user maintenance on the appliance.
- Do not use extension cords or ungrounded (two prong) adapters.

- The refrigerator must be disconnected from the source of electrical supply before attempting the installation of accessory.
- The appliance is intended to be used as is. Do not alter the specifications by enhancing any applications of the appliance.

<b>⚠ WARNING</b>
<ul style="list-style-type: none"> <li>• Keep ventilation openings, in the appliance enclosure or in the built-in structure, clear of obstruction.</li> <li>• Do not use mechanical devices or other means to accelerate the defrosting process, other than those recommended by the manufacturer.</li> <li>• Do not damage the refrigerant circuit.</li> <li>• Do not use electrical appliances inside the food storage compartments of the appliance, unless they are of the type recommended by the manufacturer.</li> <li>• Please recycle the refrigerator according to local regulators for it use flammable blowing gas and refrigerant.</li> <li>• When positioning the appliance, ensure the supply cord is not trapped or damaged.</li> <li>• Do not locate multiple portable socket-outlets or portable power supplies at the rear of the appliance.</li> </ul>

<b>⚠ DANGER</b>
<p>Risk of child entrapment. Before you throw away your refrigerator or freezer:</p> <ul style="list-style-type: none"> <li>• Take off the doors.</li> <li>• Leave the shelves in place so that children may not easily climb inside.</li> <li>• To prevent a child from being entrapped, keep out of reach of children and not in the vicinity of freezer (or refrigerator).</li> </ul>

Refrigerant and cyclopentane foaming material used for the appliance are flammable. Therefore, when the appliance is scrapped, it shall be kept away from any fire source and be recovered by a special recovering company with corresponding qualification other than be disposed by combustion, so as to prevent damage to the environment or any other harm.

Children should be supervised to ensure that they do not play with the appliance.

This appliance can be used by children aged from 8 years and above and persons with reduce physical sensory or mental capabilities or lack of experience and knowledge if they have been given supervision or instruction concerning use of the appliance in a safe way and understand the hazards involved. Children shall not play with the appliance. Cleaning and user maintenance shall not be made by children without supervision. Children aged from 3 to 8 years are not allowed to load and unload refrigerating appliances.

# IMPORTANT SAFETY INSTRUCTIONS

## FOOD SAFETY

To avoid contamination of food, please respect the following instructions:

- Opening the door for long periods can cause a significant increase of the temperature in the compartments of the appliance.
- Clean regularly surfaces that can come in contact with food and accessible drainage systems.
- Clean water tanks if they have not been used for 48 hours; flush the water system connected to a water supply if water has not been drawn for 5 days.
- Store raw meat and fish in suitable containers in the refrigerator, so that it is not in contact with or drip onto other food.
- If the refrigerating appliance is left empty for long periods, switch off, defrost, clean, dry and leave the door open to prevent mold developing within the appliance.

### ⓘ WARNING

- To avoid a hazard due to instability of the appliance, it must be fixed in accordance with the instructions.
- Connect to potable water supply only. (Suitable for ice making machine.)

## ELECTRICITY RELATED WARNINGS

- Do not pull the power cord when pulling the power plug of the refrigerator. Please firmly grasp the plug and pull it out from the socket directly.
- To ensure safe use, do not damage the power cord or use the power cord when it is damaged or worn.

### ⓘ WARNING

- Please use a dedicated power socket and the power socket shall not be shared with other electrical appliances. The power plug should be firmly contacted with the socket or else fires might be caused.
- Please ensure that the grounding electrode of the power socket is equipped with a reliable grounding line.
- In case of leakage of gas and other flammable gases, please turn off the valve of the leaking gas and then open the doors and windows Do not unplug the refrigerator and other electrical appliances considering that spark may cause a fire.

### ⊘ PROHIBIT

- **Do not use electrical appliances on the top of the appliance, unless they are of the type recommended by the manufacturer.**

## WARNINGS FOR USING

### ⊘ PROHIBIT

- **Do not arbitrarily disassemble or reconstruct the refrigerator, nor damage the refrigerant circuit; maintenance of the appliance must be conducted by a specialist**
- **Damaged power cord must be replaced by the manufacturer, its maintenance department or related professionals in order to avoid danger.**
- **Do not allow any child to get into or climb the refrigerator; otherwise suffocation or falling injury of the child may be caused.**

### ⓘ WARNING

- The gaps between refrigerator doors and between doors and refrigerator body are small, be noted not to put your hand in these areas to prevent from squeezing the finger. Please be gentle when close the refrigerator door to avoid falling articles.
- Do not pick foods or containers with wet hands in the freezing chamber when the refrigerator is running, especially metal containers in order to avoid frostbite.

### ⚠ DANGER

- Do not place heavy objects on the top of the refrigerator considering that objects may fall when close or open the door, and accidental injuries might be caused.
- Please pull out the plug in case of power failure or cleaning. Do not connect the refrigerator to power supply within five minutes to prevent damages to the compressor due to successive starts.

## WARNINGS FOR PLACEMENT OF ITEMS

### ⓘ WARNING

- Do not put flammable, explosive, volatile and highly corrosive items in the refrigerator to prevent damages to the product or fire accidents.
- Do not place flammable items near the refrigerator to avoid fires.
- The refrigerator is intended for household use, such as storage of foods; it shall not be used for other purposes, such as storage of blood, drugs or biological products, etc.
- Do not store beer, beverage or other fluid contained in bottles or enclosed containers in the freezing chamber of the refrigerator; or otherwise the bottles or enclosed containers may crack due to freezing to cause damages.

# IMPORTANT SAFETY INSTRUCTIONS

## WARNINGS FOR ENERGY

1. Refrigerating appliances might not operate consistently (possibility of defrosting of contents or temperature becoming too warm in the frozen food compartment) when sited for an extended period of time below the cold end of the range of temperatures for which the refrigerating appliance is designed.
2. The fact that effervescent drinks should not be stored in food freezer compartments or cabinets or in low-temperature compartments or cabinets, and that some products such as water ices should not be consumed too cold;
3. The need to not exceed the storage time(s) recommended by the food manufacturers for any kind of food and particularly for commercially quick-frozen food in food-freezer and frozen-food storage compartments or cabinets;
4. The precautions necessary to prevent an undue rise in the temperature of the frozen food while defrosting the refrigerating appliance, such as wrapping the frozen food in several layers of newspaper.
5. The fact that a rise in temperature of the frozen food during manual defrosting, maintenance or cleaning could shorten the storage life.
6. The necessity that, for doors or lids fitted with locks and keys, the keys be kept out of the reach of children and not in the vicinity of the refrigerating appliance, in order to prevent children from being locked inside.

## WARNINGS FOR DISPOSAL

### ⊘ PROHIBIT

Refrigerant and cyclopentane foaming material used for the refrigerator are flammable. Therefore, when the refrigerator is recycled, it shall be kept away from any fire source and be recovered by a special recovering company with corresponding qualification other than be disposed by combustion, so as to prevent damage to the environment or any other harm.

### ⓘ WARNING

- When the refrigerator is recycled, disassemble the doors, and remove gasket of door and shelves; put the doors and shelves in a proper place, so as to prevent trapping of any child.
- When the refrigerator is recycled, cut the connection cable, and discard it, to prevent any future misuse of the appliance.

### Correct Disposal of this product



This marking indicates that this product should not be disposed with other household wastes. To prevent possible harm to the environment or human health from uncontrolled waste disposal, recycle it responsibly to promote the sustainable reuse of material resources. To return your used device, please use the return and

collection systems or contact the retailer where the product was purchased. They can take this product for environmental safe recycling.

### ⓘ WARNING

**WARNING:** Cancer and Reproductive Harm -  
[www.P65Warnings.ca.gov](http://www.P65Warnings.ca.gov)

# INSTALLATION INSTRUCTIONS

## SPACE REQUIREMENT

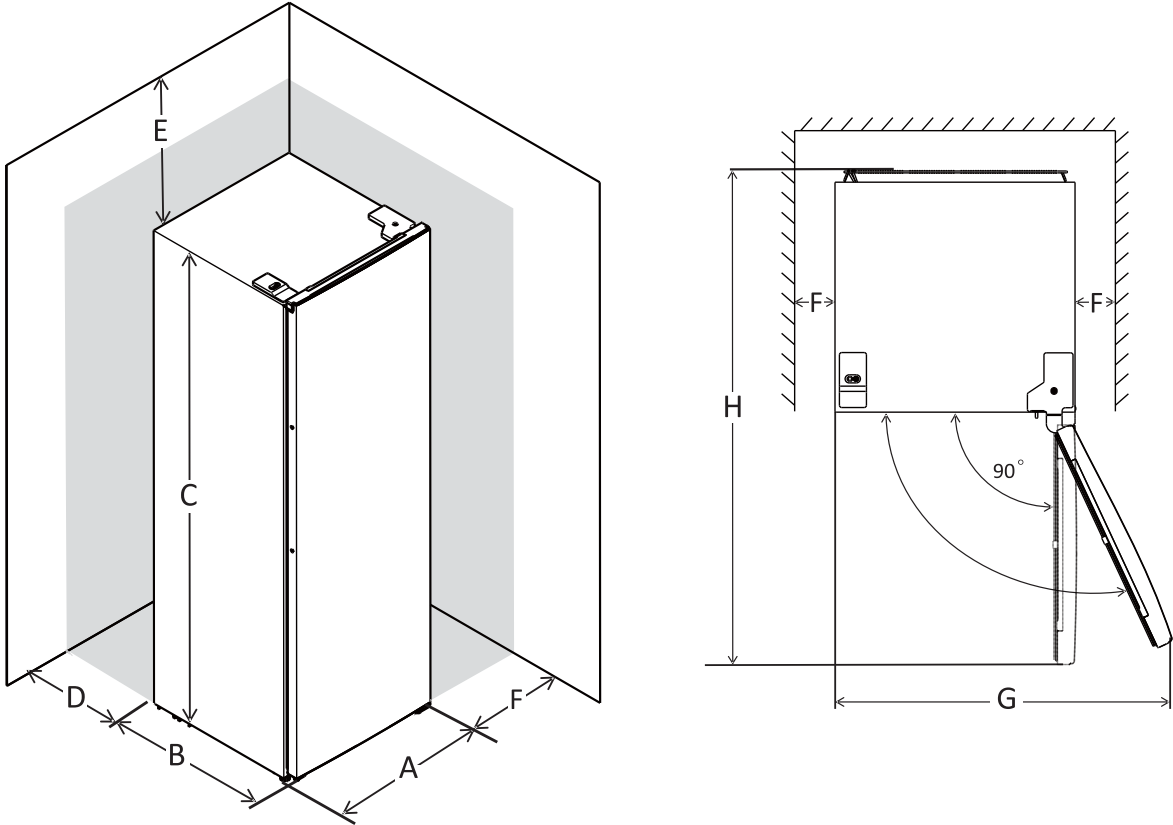

DIMENSIONS	SIZE (IN)
A	23.6
B	27.0
C	72.8
D	Min. 2.0
E	Min. 2.0
F	Min. 2.0
G	37.8
H	38.6

Depth without door is 24.4"

# INSTALLATION INSTRUCTIONS

## INSTALLATION LOCATION

- This refrigerator is designed for indoor, household use only.
- Keep away from heat and avoid direct sunlight or places near a heat source, such as an oven or a radiator.
- Do not place the refrigerator in moist or watery places to prevent rust or reduction of insulating effect to affect the electrical insulation properties of the refrigerator.
- The refrigerator is placed in a dry and well-ventilated indoor place.
- The ground shall be flat, and sturdy (rotate the adjustable leg left or right to adjust for leveling if unstable.)
- The temperature of the location ranges from a minimum of 55°F to a maximum of 110°F. However, for better energy usage and superior cooling, the temperature is preferred to be between 60°F and 90°F.
- For proper air circulation and electric connections, allow a 2" clearance on each side and behind the refrigerator. Allow a 2" clearance at top of the refrigerator.
- Spare enough space for convenient opening of the doors and drawers, especially when the refrigerator is installed next to a fixed wall to allow the door to swing open.

## ELECTRICAL CONNECTION

Before plugging in, ensure that the voltage and frequency shown on the rating plate correspond to your domestic power supply. The appliance must be grounded. The power supply cable plug is provided with a contact for this purpose. If the domestic power supply socket is not grounded, connect the appliance to a separate ground in compliance with current regulations, consulting a qualified electrician.



The manufacturer declines all responsibility if the above safety precautions are not observed.

This appliance complies with the E.E.C. Directives.

## DOOR REVERSIBILITY

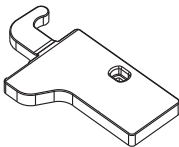
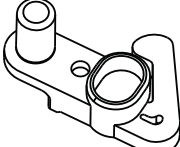
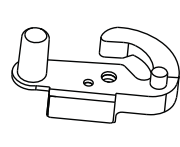
Before reversing the door, please be prepared below tools and material: phillips head screwdriver, socket wrench, wrench and components included in the poly bag:

<p>Left Door Hinge Cover x 1</p> 	<p>Left Aid-Closer on Upper Door x 1</p> 	<p>Left Aid-Closer on Lower Door x 1</p> 
--	--	--

TOOLS TO PREPARE		
<p>Phillips Head Screwdriver</p> 	<p>Socket Wrench</p> 	<p>Wrench</p> 

1. Unscrew top hinge cover and disconnect connector of door switch.

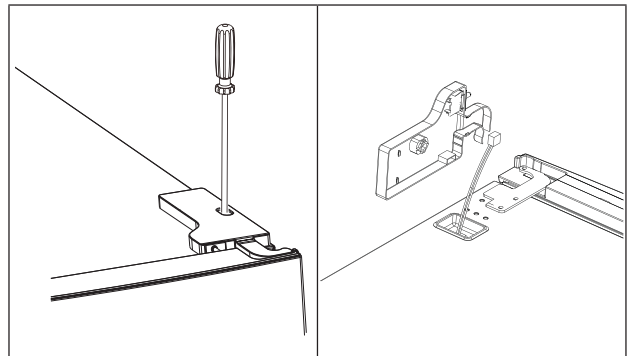

2. Unscrew top hinge with screwdriver or 1/4" socket wrench and remove the upper door.

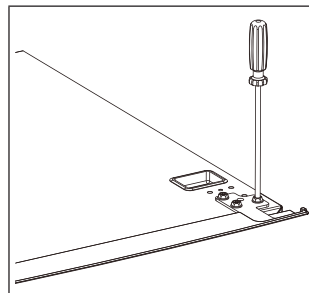

3. Remove the pin with a wrench or 3/8" socket wrench and flip the hinge bracket. Then refit the pin to the hinge bracket.

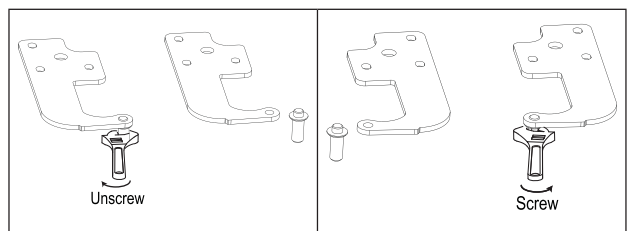



# INSTALLATION INSTRUCTIONS

4. Move door switch from right hinge cover to left hinge cover in accessory bag.

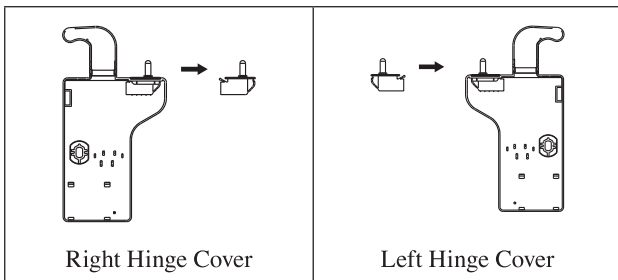

5. Move top left cover to right side.

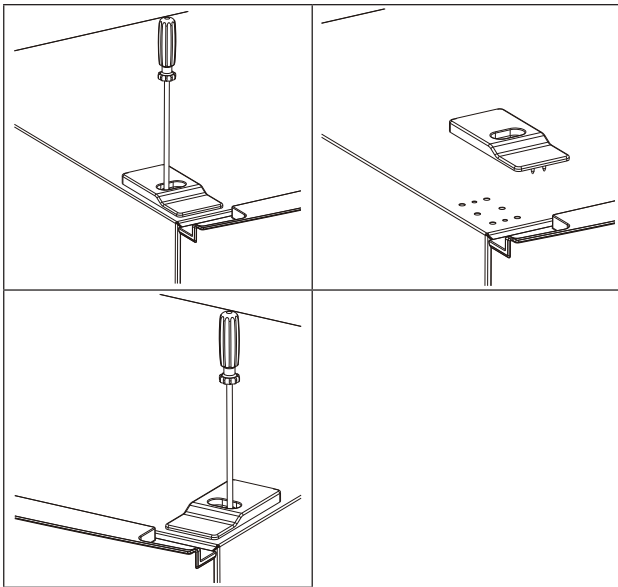

6. Take off the upper door, take out the screw from the middle hinge by cross screwdriver or 1/4" socket wrench, then take off the lower door.

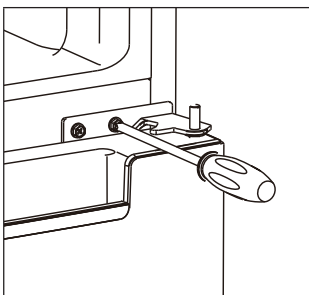

7. Unscrew bottom hinge with 3/8" socket wrench

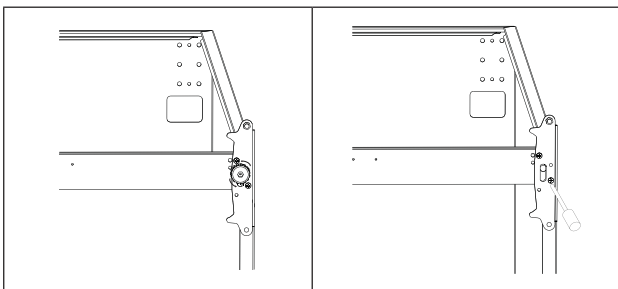

8. Unscrew and remove the bottom hinge pin with wrench or 3/8" socket wrench, turn the bracket over and refit it.

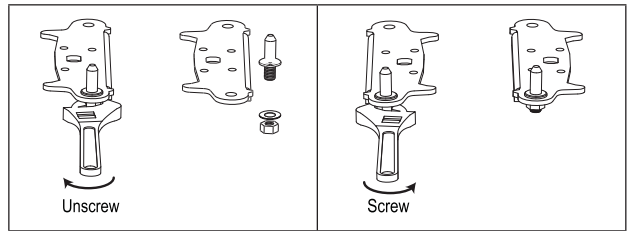

9. Refit the bracket fitting the bottom hinge pin on the left side. Replace both adjustable feet.

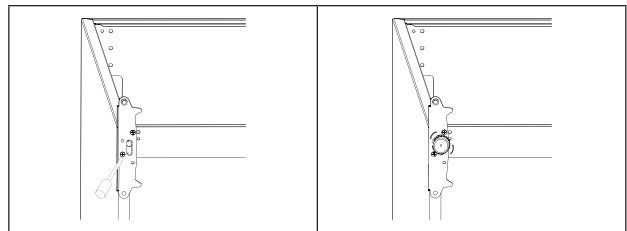

10. Remove aid-closers from bottom of upper and lower doors with screwdriver.

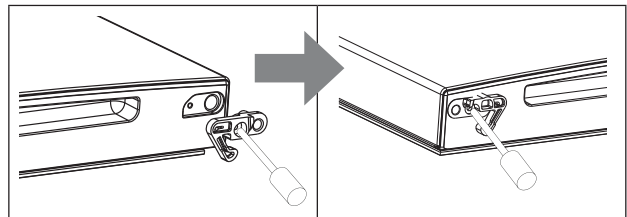

Then take new aid-closers from accessory bag and install them to the left side.

11. Move the hinge hole covers from left side to right side. Place the lower door, flip and refit the middle hinge (that you removed on step 6).

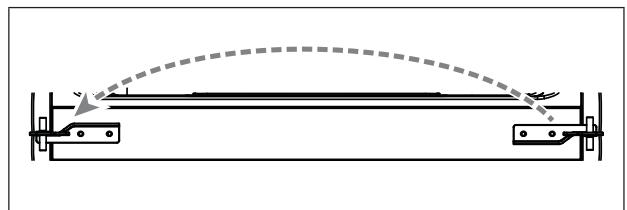

12. Refit upper door, please ensure the door is align with the cabinet to make sure door gasket is sealed to the cabinet tightly. Then connect the door with the cabinet by tightening the screw to the top hinge with a screwdriver or socket wrench.

# INSTALLATION INSTRUCTIONS

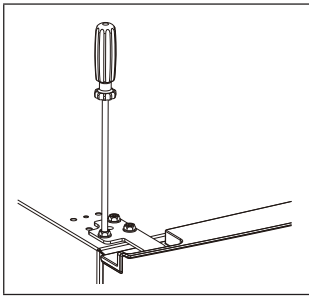

13. Replace top hinge cover. Before screw the cover, connect terminals of door switch.

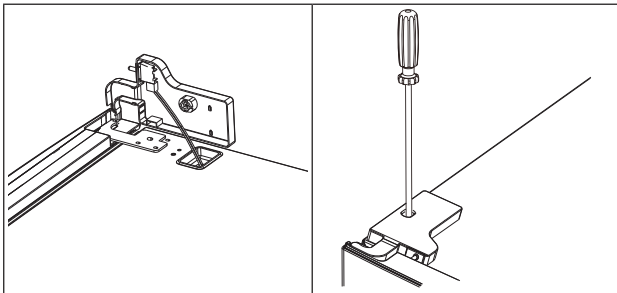

If you only want to disassemble door follow steps 1-3 for disassembly.

## LEVELLING THE UNIT

To do this adjust the two leveling feet at front of the unit.

If the unit is not level, the doors and magnetic seal alignments will not be covered properly.

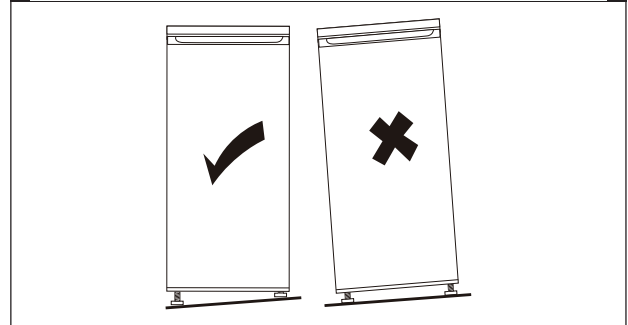
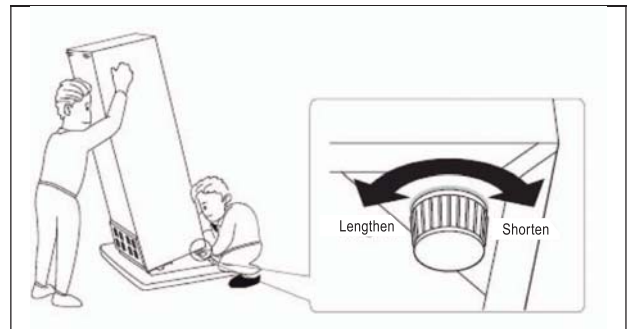

## HOW TO REMOVE SHELVES

To remove the removable shelf: First, lift up the rear end of shelf, and then pull the shelf out.

# APPEARANCE OVERVIEW

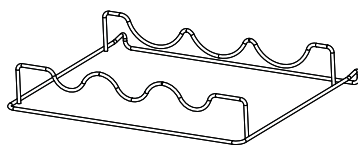
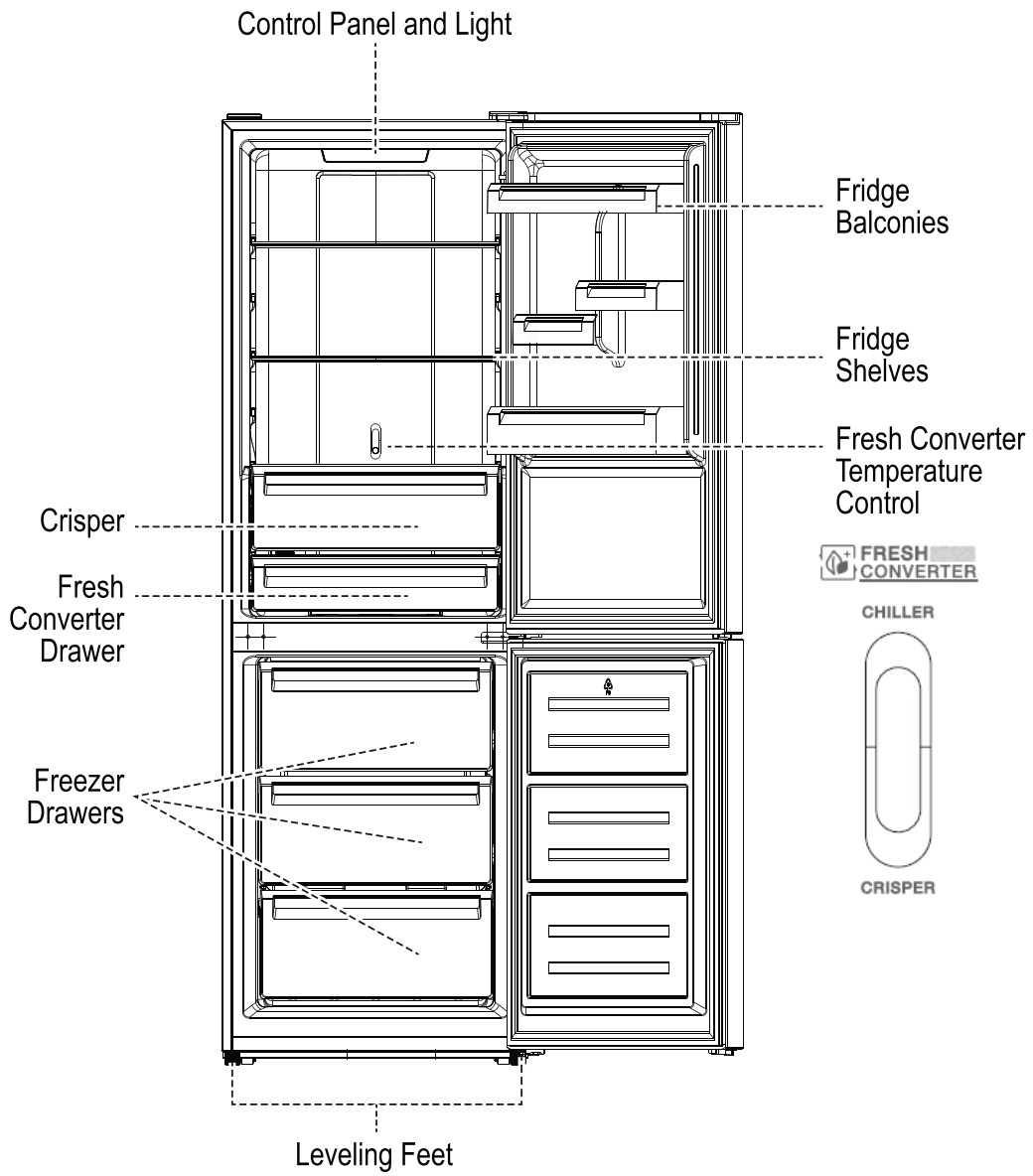

Wine Rack (supplied)

# USER INTERFACE

## SETTING PANEL

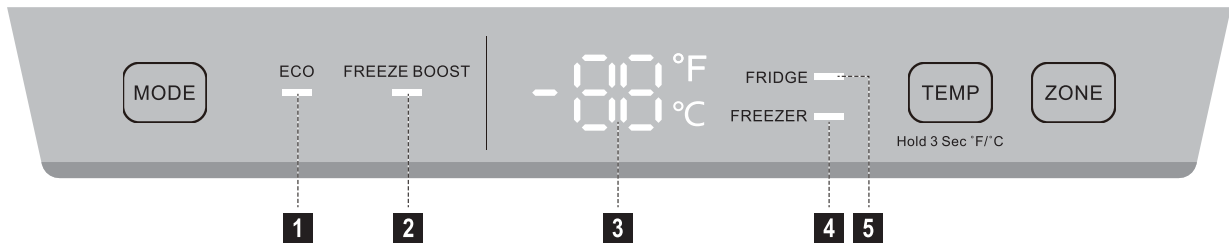

### BUTTONS & TEMPERATURE SETTING

#### MODE

Press [MODE] to select [ECO] Mode or [FREEZE BOOST] Mode, and please wait until the flash turns to continuous light, then the Mode is selected successfully.

The default mode is Normal Mode. If not, press [MODE] until [ECO] & [FREEZE BOOST] unlighted.

Under Normal Mode, you can set the temperature of Refrigerator and Freezer compartment.

#### ZONE

Under Normal Mode, press [ZONE] to select either Refrigerator or Freezer to which you plan to adjust the temperature.

#### TEMP

Under Normal Mode, press [TEMP] to adjust the temperature of Refrigerator or Freezer compartment.

Press [TEMP] and hold longer than 3 seconds to switch between Fahrenheit and Celsius.

The setting temperature of Freezer and Refrigerator compartment cycles as follows.

#### REFRIGERATOR TEMPERATURES

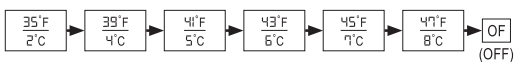

#### FREEZER

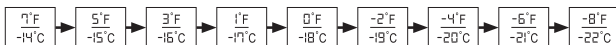

### DISPLAY AND LIGHT

- 1 It will light when ECO Mode is selected by button [MODE].
- 2 It will light when Freeze Boost Mode is selected by button [MODE].
- 3 It shows setting temperature of Refrigerator or Freezer compartment in Fahrenheit or Celsius.
- 4 It will light when the Freezer compartment is selected by button [ZONE].
- 5 It will light when the Refrigerator compartment is selected by button [ZONE].

### OPTIONAL MODES

#### ECO MODE

In this mode, the temperature of fridge and freezer is automatically set at 41°F and 0°F. The temperature of two compartments are not adjustable. The appliance runs at low energy consumption.

Selected by pressing [Mode] button 1 time.

#### FREEZE BOOST

In this mode, the temperature of freezer is automatically set at -13°F. The temperature in freezer will be reduced rapidly.

If you plan to freeze a large number of food in one time, select FREEZE BOOST mode 24 hours ahead.

In this mode, the temperature of fridge is still adjustable. The appliance will go back to previous running mode automatically after 50 hours.

Selected by pressing [Mode] button 2 times

#### VACATION MODE

Use VACATION MODE to switch off fridge compartment while freezer continues operating to save energy on your vacation.

Selected by pressing Mode button 3 times.

#### DOOR OPEN ALARM

If door keeps open longer than 60 seconds, alarm will rise automatically. Close the door immediately to save energy.

## DAILY USE

### FREEZING FRESH FOOD

- The freezer compartment is suitable for freezing fresh food and storing frozen and deep-frozen food for a long time.
- Place the fresh food to be frozen in the bottom compartment.
- The maximum amount of food that can be frozen in 24 hours is specified on the rating plate.
- The freezing process lasts 24 hours: during this period do not add other to be frozen.

### STORING FROZEN FOOD

When first starting-up or after a period out of use, before putting the product in the compartment, let the appliance run at least 2 hours on the higher settings.

**IMPORTANT!** In the event of accidental defrosting, for example, the power has been off for longer than the value shown in the technical characteristics chart under "rising time", the defrost food must be consumed quickly or cooked immediately and then re-frozen (after cooked).

### THAWING

Deep-frozen or frozen food, prior to be used, can be thawed in the freezer compartment or at room temperature, depending on the time available for this operation.

Small pieces may even be cooked still frozen, directly from the freezer. In this case, cooking will take longer.

## HELPFUL HINTS AND TIPS

### HINTS FOR FREEZING

To help you make the most of the freezing process, here are some important hints:

- The maximum quantity of food which can be frozen in 24 hours is shown on the rating plate.
- The freezing process takes 24 hours. No further food to be frozen should be added during this period.
- Only freeze top quality, fresh and thoroughly cleaned foods.
- Prepare food in small portions to enable it to be rapidly and completely frozen and to make it possible subsequently to thaw only the quantity required.
- Wrap up the food in aluminium foil or polythene and make sure that the packages are airtight.
- Do not allow fresh, unfrozen food to touch food which is already frozen, thus avoiding a rise in temperature of the later.
- Lean foods store better and longer than fatty ones. Salt reduces the storage life of food.
- Water ices, if consumed immediately after removal from the freezer compartment, can possibly cause the skin to be freeze burnt.
- It is advisable to show the freezing in date on each individual pack to enable you removal from the freezer compartment, can possible cause the skin to be freeze burnt.
- It is advisable to show the freezing in date on each individual pack to enable you to keep tab of the storage time.

### HINTS FOR STORAGE OF FROZEN FOOD

To obtain the best performance from this appliance, you should:

- Make sure that the commercially frozen foods were adequately stored by the retailer.
- Be sure that frozen foods are transferred from the food store to the freezer in the shortest possible time.
- Not open the door frequently or leave it open longer than absolutely necessary.
- Once defrosted, food deteriorates rapidly and cannot be refrozen.
- Do not exceed the storage period indicated by the food manufacture.
- Do not store warm food or evaporating liquids in the refrigerator.
- Do cover or wrap the food, particularly if it has a strong flavour.

### HINTS FOR REFRIGERATION

Useful hints:

- Make (all types): wrap in polythene bags and place on the glass shelves above the vegetable drawer.
- For safety, store in this way only one or two days at the most.
- Cooked foods, cold dishes, etc.: these should be covered and may be placed on any shelf.
- Fruit and vegetables should be thoroughly cleaned and placed in the special drawer(s) provided.
- Butter and cheese should be placed in special airtight containers or wrapped in aluminum foil or polythene bags to exclude as much air as possible.
- Milk bottle should have a cap and should be stored in the balconies on the door.
- Bananas, potatoes, onions and garlic, if not packed, must not be kept in the fridge.

### FRESH ZONE TEMPERATURE CONTROL

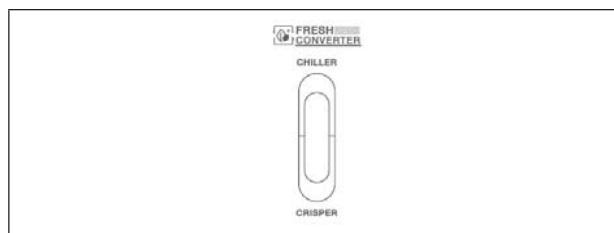

- Temperature of the fresh can be adjusted according to the type of storage food.
- Push the knob upward from the bottom, temperature in the fresh zone will be gradually decreased.
- When the knob is placed at the "CRISPER" position, the fresh zone can be functioned as a crispener zone and maintain the appropriate temperature and humidity for fruits and vegetable.
- When the knob is placed at the "CHILLER" function, it is suitable for short-term storage of fish or other fresh food. The food will keep fresh but not frozen, which makes it the best choice for storing fresh food.

## DAILY USE

---

- Tips: When you choose "CHILLER" function, it is recommended to set the refrigerator temperature below 39 °F and preserved lead-time no more than 3 days, in order to keep the best freshness.

### ERROR CODES

If there is fault, the display will show ERROR codes.

ERROR CODES	AREAS WITH FAULT
E0	Signal transmission between control board and main board. Probably defects of harness (wire and connectors), main board or control board
E1	Temperature sensor of fridge compartment
E2	Temperature sensor of freezer compartment
E3	Defrost temperature sensor in freezer compartment
E4	Fan motor in evaporator room of freezer compartment
E5	Defrost heater or the fuse connected with heater

When ERROR codes appear, call 1-866-437-4277.

## FIRST USE

### CLEANING THE INTERIOR

Before using the appliance for the first time, wash the interior and all internal accessories with lukewarm water and some neutral soap to remove the typical smell of brand new product, then dry thoroughly.

**IMPORTANT!** Do not use detergents or abrasive powders, these will damage the finish.

## CLEANING

For hygienic reasons the appliance interior, including interior accessories, should be cleaned regularly.

### **CAUTION**

The appliance may not be connected to the mains during cleaning. Danger of electrical shock! Before cleaning, switch the appliance off and disconnect the power supply or switch off or turn out the circuit breaker or fuse.

Never clean the appliance with a steam cleaner. Moisture could accumulate in electrical components, danger of electrical shock! Hot vapors can lead to the damage of plastic parts.

The appliance must be dry before it is placed back into service.

**IMPORTANT!** Ethereal oils and organic solvents can damage plastic parts, e.g. lemon juice or the juice from orange peel, butyric acid, cleanser that contain acetic acid.

- Do not allow such substance to come into contact with the appliance parts.
- Do not use any abrasive cleaners.
- Remove the food from the freezer. Store them in a cool place, well covered.
- Switch the appliance off and unplug or switch off or turn out the circuit breaker or fuse.
- Clean the appliance and the interior accessories with cloth and lukewarm water. After cleaning, wipe with fresh water and rub dry.
- After everything is dry, place appliance back into service.

## REPLACE THE LAMP

The internal light is a LED type. To replace the lamp, contact 1-866-437-4277.

# TROUBLE SHOOTING

## ▲CAUTION

Before troubleshooting, disconnect the power supply. Only a qualified electrician or competent person must do the trouble shooting that is not in this manual.

**IMPORTANT!** There are some sounds during normal use (compressor, refrigerant circulation).

PROBLEM	POSSIBLE CAUSE	SOLUTION
Appliance does not work	AC Cord is not plugged in or is loose	Insert AC Cord
	Fuse has blown or is defective	Check fuse, replace if necessary
	Electrical Outlet is defective	Electrical outlet or circuit breaker malfunctions are to be corrected by an electrician
Appliance freezes or cools too much	Temperature is set too cold or the appliance runs at FREEZE BOOST modes	Refer to the Temperature Setting section
	Temperature is not properly adjusted	Refer to the Temperature Setting section
The food is not frozen enough	A large quantity of warm food was placed in the appliance within the last 24 hours	Turn the temperature regulation to colder setting temporarily
	The appliance is near a heat source	Refer to the Installation Location section
Heavy build up of frost on the door seal	Door seal in not airtight	Carefully warm the leaking section of the door seal with a hair dryer (on a cool setting). At the same time, shape the warmed door seal by hand such that it sits correctly.
	Appliance is not level	Re-adjust the feet
Unusual noise	The appliance is touching the wall or other objects	Move the appliance slightly
	A component, e.g. a pipe on the rear of the appliance is touching another part of the appliance or the wall	<b>If necessary</b> , carefully bend the component out of the way
Side panel is hot	Condenser is inside the panel	It's normal

If the malfunction shows again, contact the Sharp customer support (1-866-437-4277) to dispatch a service technician.

Please record your model number and serial number below.

Model number \_\_\_\_\_

Serial number \_\_\_\_\_

# SHARP

SHARP ELECTRONICS OF CANADA LTD. • 335 Britannia Road East • Mississauga, Ontario L4Z 1W9 • Canada