

SHARP | Simply Better Living

MICROWAVE DRAWER

SMD2480CSC



SPECIFICATIONS

FEATURES

Finish	Stainless Steel, Black Glass
Drawer Opening	"Easy Wave Open" Motion Sensor or Open/Close Button
Width	24"
Capacity (cu. ft.)	1.2
Output Power (watts)	950
Interior Light	LED
Timer/Settings	Yes
Open/Close	Yes
Start/+30 Sec	Yes
Stop/Clear	Yes
Power Level	11
Clock	Yes
Multi-Stage Cooking	4
Control Lock	Yes
Demo Mode	Yes
Microwave ON Indicator	Yes
End of Cooking Reminder	Yes
Auto Start	Yes
Standby Mode	Yes

CONTROL PANEL

Control Panel Location	Center/Top
Control Panel Type	Glass Touch, Drop-Down 45° Angle
Display Type	LCD
Display Color	White on Black Background

COOKING / MENU PRESETS

Popcorn	Sensor
Reheat	Sensor
Defrost Settings	Ground Meat, Steaks/Chops, Boneless Poultry, Bone-in Poultry, Roast, Casserole or Soup
Sensor Cook	Baked Potatoes, Sweet Potatoes, Fish/Seafood, Brown Rice, White Rice, Quick Fresh Vegetables, Longer Fresh Vegetables, Steamer Bag, Frozen Vegetables, Ground Meat, Frozen Entrees
Melt, Soft & Warm Options	Butter, Chocolate, Ice Cream, Cream Cheese, Syrup, Dessert Topping
Other Menus	Beverage Reheat, Hot Water, Hot Cereal

ADDITIONAL FEATURES

Oven Floor	Patterned Glass
Flush Mount	Yes, vent incorporated in the bottom of drawer face

OPTIONAL ACCESSORY

Product Name	Extension Kit for 30" width
Model	SKMD30E3DS
Colour	Stainless Steel with Black Glass
UPC	074000620629

ADDITIONAL SPECIFICATIONS

Oven Interior (w x h x d)	17-5/16" x 7-1/8" x 16-9/16"
Power Source	120V, 60Hz / 14.5A / 1.67 KW

DIMENSIONS & WEIGHT (in./lbs.) (w x h x d)

Standard Mount Cutout Dimensions	22-1/8" x 15-9/16" x 23-1/2"
Flush Mount Cutout Dimensions	23-7/8" x 16-1/4" x 23-1/2"
Product Dimensions	23-5/8" x 16.0" x 23-7/16"
Shipping Dimensions	29-1/4" x 21-1/2" x 27-7/8"
Product Weight / Shipping Weight	74.0 lbs. / 85.8 lbs.

WARRANTY / UPC

Parts	1 year
Labour	1 year
Magnetron Tube	5 years (parts only)
UPC	074000620551

Internal capacity calculated by measuring maximum width, depth and height. Actual capacity for holding food is less.

Product specifications and design are subject to change without notice.

© 2018 Sharp Electronics Corporation. All rights reserved.

Sharp, Microwave Drawer, Supersteam+, Healsio, Plasmacluster and all related trademarks are trademarks or registered trademarks of Sharp Corporation and/or its affiliated companies. All other trademarks are property of their respective owners.

SIMPLY BETTER LIVING

At Sharp Electronics of Canada, we are committed to Simply Better Living. Our innovative home appliance products are SIMPLE to use, BETTER than the competition, and encourage a HEALTHY LIFESTYLE.

SHARP ELECTRONICS OF CANADA LTD.
335 Britannia Road East, MISSISSAUGA, ONTARIO L4Z 1W9
Tel: 905-568-7140 . www.sharp.ca

SHARP
Be Original.

SMD2480CSC

The following are measurements only. Do not use to install microwave drawer.

For detailed installation instructions, please refer to the installation manual

24" MICROWAVE DRAWER PRODUCT DIMENSIONS

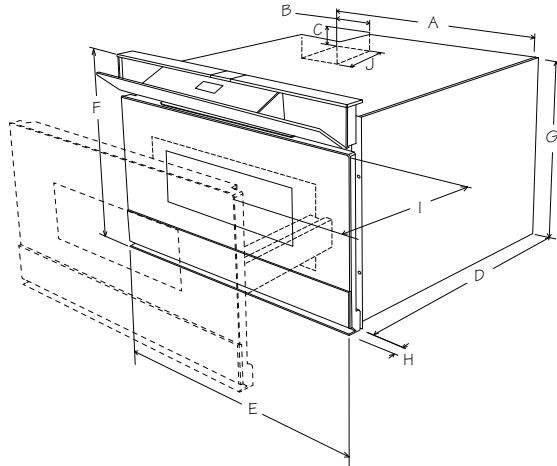

- A. 21-5/8" (549.28 mm)
- B. 4-11/16" (119.06 mm)
- C. 1-3/4" (44.45 mm)
- D. 21-7/8" (555.63 mm)
- E. 23-5/8" (600.07 mm)
- F. 16" (406.4 mm)
- G. 14-19/32" (370.68 mm)
- H. 1-17/32" (38.89 mm) door thickness
- I. 15" (381 mm) auto drawer opening
- J. 4" (101 mm)

24" MICROWAVE DRAWER STANDARD MOUNT MEASUREMENTS

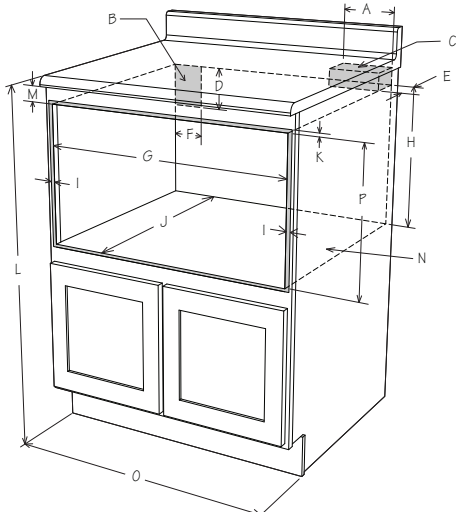

- A. 6" (152.40 mm)
- B. Suggested electrical outlet location
- C. Anti-Tip block
- D. 5" (127 mm)
- E. 3-1/2" (88.90 mm)
- F. 4" (101.60 mm)
- G. 22-1/8" (561.97 mm) opening
- H. 14-13/16" (376.24 mm) to bottom of Anti-Tip block
- I. Allow 7/8" (22.22 mm) overlap
- J. 23-1/2" (596.90 mm) min. depth
- K. Allow 7/16" (11.11 mm) overlap
- L. 36" (914.40 mm) countertop height
- M. Allow 7/16" (11.11 mm) min. space
- N. Floor must support 100 lb/45.4 kg
- O. 24" (609.60 mm) cabinet min.
- P. 15-9/16" (395.29 mm) opening

24" MICROWAVE DRAWER FLUSH MOUNT MEASUREMENTS

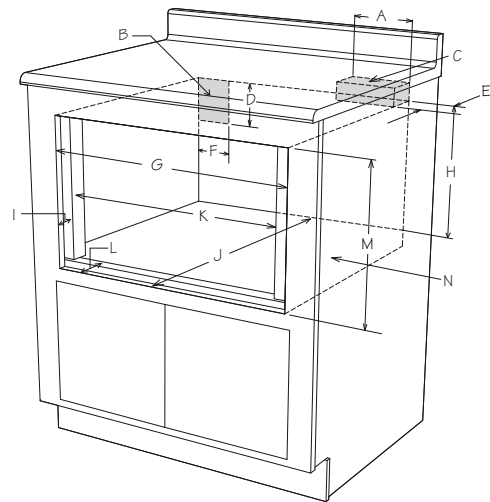

- A. 6" (152.40 mm)
- B. Suggested electrical outlet location
- C. Anti-Tip block
- D. 5" (127 mm)
- E. 3-1/2" (88.90 mm)
- F. 4" (101.60 mm)
- G. 23-7/8" (606.43 mm)
- H. 14-13/16" (376.24 mm) to bottom of Anti-Tip block
- I. 1-1/16" (26.97 mm)
- J. 23-1/2" (596.90 mm) min. depth
- K. 22-1/8" (561.97 mm)
- L. 1-17/32" (38.89 mm) to front of shelf
- M. 16-1/4" (412.75 mm) opening
- N. Floor must support 100 lb (45.4 kg)

SIMPLY BETTER LIVING

At Sharp Electronics of Canada, we are committed to Simply Better Living. Our innovative home appliance products are SIMPLE to use, BETTER than the competition, and encourage a HEALTHY LIFESTYLE.