

60CM (Approx 24") Built-in Microwave  
 Stainless Steel  
 EAN13: 8017709247959

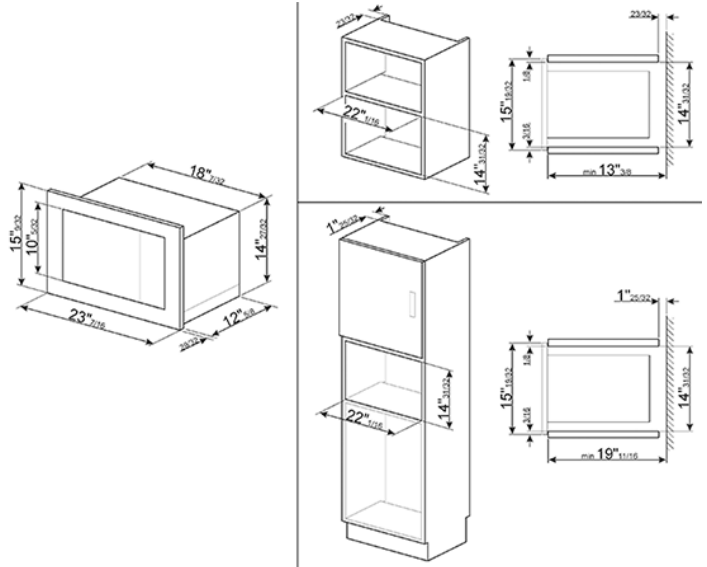

• Installation: With frame kit • Power supply: Electric • Cooking Method: Microwave with grill • Control: Electromechanical • Programs/Functions • No. of functions: 6 • Automatic programs: 8 • Controls • Display: 1 LED • Type of controls: Push buttons • Opening: Mechanical button • No. of controls: 1 • Control knobs: Push-push • Control color: Steel effect • Bottom Color: Steel effect • Options • Timer: Electronic • Time-setting options: End cooking • End of cooking acoustic alarm • Control Lock / Child Safety • Quick start option • Technical Features • Cavity material: Stainless steel • No. of lights: 1 • Type light: LED • Turn table • Turn table dimensions: 9.65" • Lighting when door is opened • Grill type: Heating element • Grill - power: 1000 W • Door opening: Side-opening • No. of glass panel: 1 • Security Thermostat • Cooling system: Tangential • Microwave door protection screen • Microwave stop when door is opened • Net dimensions of the cavity interior (HxWxD): 8.58"x12.40"x11.61" • Microwave effective power: 800 W • Accessories Included • Grid: 1 • Frame • Electrical Connection • Electrical connection rating (W): 1250 W • Current: 5.4 Amp • Voltage (V): 120 V • Frequency (Hz): 60 Hz • Power supply cable length: 59"

## Functions

