

## FMIU020X Available soon

60CM (Approx 24") Built-in Microwave  
Stainless Steel

EAN13: 8017709247959

Installation: With frame kit

Power supply: Electric

Cooking Method: Microwave with grill

Control: Electromechanical

### Programs/Functions

No. of functions: 6

Automatic programs: 8

### Controls

Display: 1 LED

Type of controls: Push buttons

Opening: Mechanical button

No. of controls: 1

Control knobs: Push-push

Control color: Steel effect

Botton Color: Steel effect

### Options

Timer: Electronic

Time-setting options: End cooking

End of cooking acoustic alarm

Control Lock / Child Safety

Quick start option

### Technical Features

Cavity material: Stainless steel

No. of lights: 1

Type light: LED

Turn table

Turn table dimensions: 9.65"

Lighting when door is opened

Grill type: Heating element

Grill - power: 1000 W

Door opening: Side-opening

No. of glass panel: 1

Security Thermostat

Cooling system: Tangential

Microwave door protection screen

Microwave stop when door is opened

Net dimensions of thr cavity interior (HxWxD): 8.58"x12.40"x11.61"

Microwave effective power: 800 W

### Accessories Included

Grid: 1

Frame

### Electrical Connection

Electrical connection rating (W): 1250 W



Current: 5.4 Amp

Voltage (V): 120 V

Frequency (Hz): 60 Hz

Power supply cable length: 59"

## Functions

---



**SMEG U.S.A. INC.**  
**A&D BUILDING**  
**150 EAST 58th STREET, 7th FLOOR**  
**NEW YORK, NY, 10155**  
**Tel. +1 212 265 5378**  
**Fax +1 212 265 5945**



---

## Main Oven

---



### Broiler:

For rapid cooking and browning of foods. Best results can be obtained by using the top shelf for small items, the lower shelves for larger ones, such as chops or sausages. For half grill heat is generated only at the centre of the element, so is ideal for smaller quantities.



### Pizza microwave:

Pizza microwave



### Defrost at weight:

Defrost at weight



### Defrost at time:

Defrost at time



### Microwave:

Penetrating straight into the food, microwaves cook very quickly and with considerable energy savings. Suitable for cooking without fat, they are also able to thaw and heat food without altering its original appearance and aroma. The microwave function can also be combined with conventional functions with all the resulting advantages. Ideal for all types of food.



### Microwave + broil element:

To achieve a combined cooking with broil that cooks the outside whilst assuring an internal cooking thanks to the microwave function.

---



# FMIU020X

microwave  
24"  
stainless steel

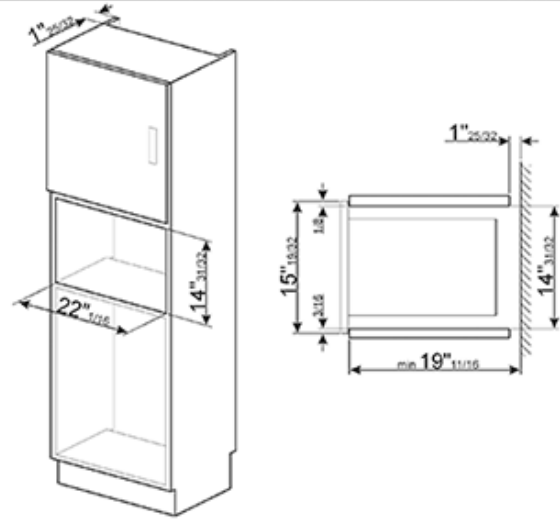
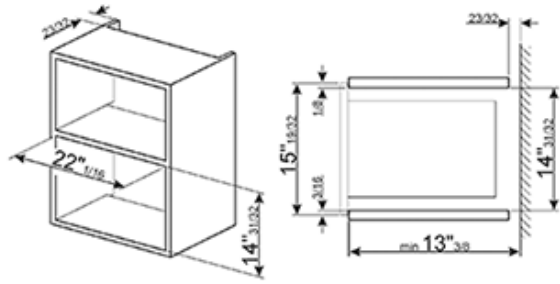
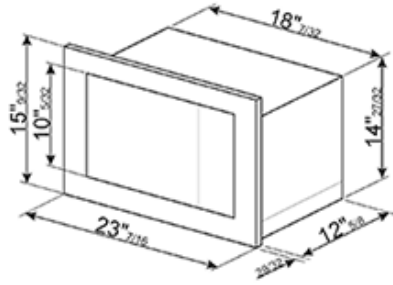

SMEG U.S.A. INC.  
A&D BUILDING  
150 EAST 58th STREET, 7th FLOOR  
NEW YORK, NY, 10155  
Tel. +1 212 265 5378  
Fax +1 212 265 5945