

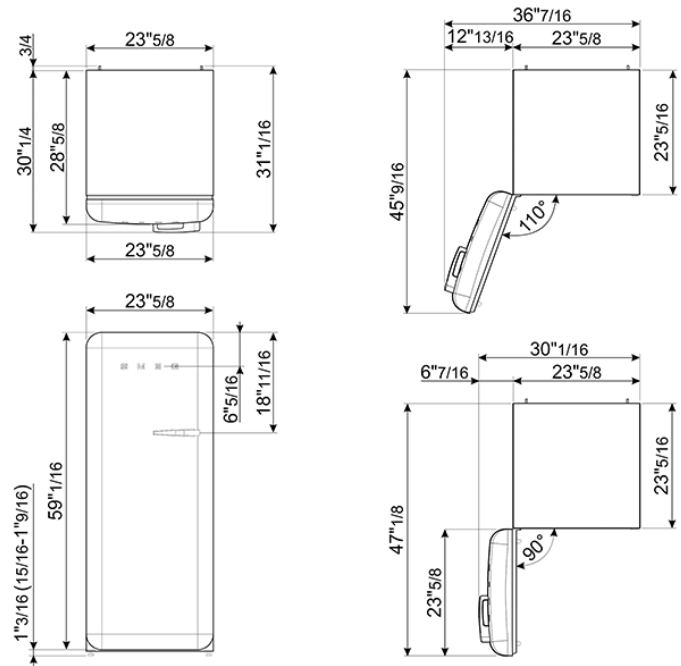

FAB28ULBL3

'50s STYLE FRIDGE WITH ICE COMPARTMENT, BLACK,
LEFT HAND HINGE, 60 CM (APPROX 24")
EAN13: 8017709271725



• **REFRIGERATOR** • Multiflow Cooling System • Fresh food capacity: 9 cu ft • Life plus zone 28 - 37°F • LED internal light • Automatic defrost • 3 adjustable glass shelves • Glass crisper cover • Fruit and vegetables drawer on telescopic guides • Inner door with 1 adjustable shelf and • 1 bottle shelf with wire support • **FREEZER** • Frozen food capacity: 0.92 cu ft • Ice cube tray • **DOOR** • 1 bin with transparent cover • 1 bottle storage bin • 2 adjustable bins • **TECHNICAL FEATURES** • Energy consumption: 230 kWh/year • Voltage: 120 V • Frequency: 60 Hz • Noise level: 38 dB(A) • Dimensions (HxWxD): 60 1/4" x 23 2/3" x 30 1/4" (handle included) • Dimensions door opened at 90° (HxWxD): 60 1/4" x 30 1/16" x 47 1/8" • Net weight: 156 lbs

Functions

