

50'S Style Refrigerator with ice compartment,
Pastel Green, Left hand hinge
EAN13: 8017709096618

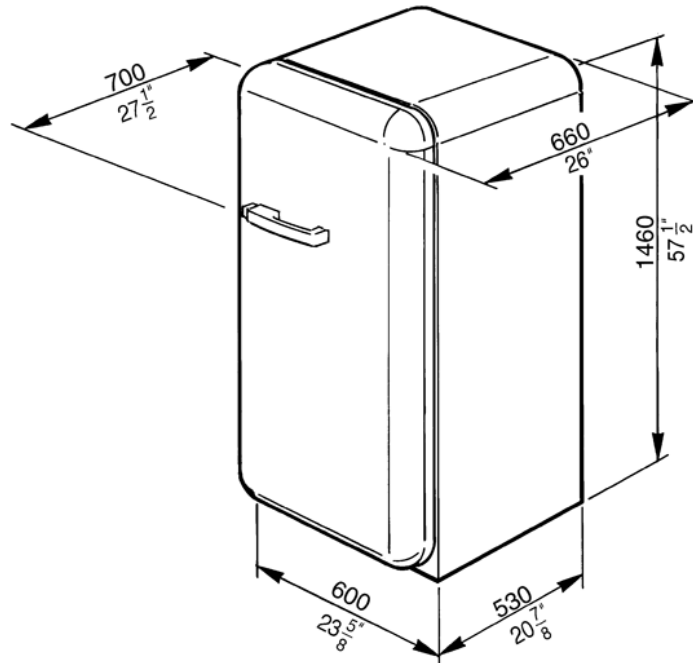

• Capacity 9.22 Cu. Ft. • REFRIGERATOR • Interior light • 3 adjustable glass shelves • 1 bottle storage shelf • 1 fixed glass shelf • 1 fruit and vegetable container • 1 dairy box • DOOR • 2 adjustable covered bins • 2 bottle storage bins • 4 adjustable bins • 2 egg bins • FREEZER COMPARTMENT: • 1 Ice cube tray • Climatic class: T • Energy consumption: 305 kWh/ year • Voltage: 120 V • Current: 10 A • Frequency: 60 Hz • Dimensions (h x w x d) 57½ x 23⅝ x 27½ inches • Gross weight: 181.4 lbs • Net weight: 156.5 lbs • A gap of 12 ½" inches must be left on the hinged side of the product to allow the door to open

Versions

• FAB28UVL - Pastel green, hinges on the left • FAB28UOR - Orange, hinges on the right • FAB28UOL - Orange, hinges on the left • FAB28UVER - Lime green, hinges on the right • FAB28UVEL - Lime green, hinges on the left • FAB28UNER - Black, hinges on the right • FAB28UNEL - Black, hinges on the left • FAB28UROR - Pink, hinges on the right • FAB28UROL - Pink, hinges on the left • FAB28URR - Red, hinges on the right • FAB28URL - Red, hinges on the left • FAB28UBLR - Blue, hinges on the right • FAB28UBLL - Blue, hinges on the left • FAB28UPR - Cream, hinges on the right • FAB28UPL - Cream, hinges on the left • FAB28UAZR - Pastel blue, hinges on the right • FAB28UAZL - Pastel blue, hinges on the left • FAB28UXR - Silver, hinges on the right • FAB28UXL - Silver, hinges on the left