



## TRU90X New product

### Victoria

Free-standing Dual Fuel Cavity "Victoria" Range  
Approx. 36" Stainless Steel

EAN13: 8017709194970

#### Exclusive Traditional Style

Electronic clock and program feature

Full width continuous grates

Stainless steel storage drawer beneath the oven

5 1/3" Stainless steel backsplash

#### Multifunction electric oven

8 cooking modes

Timer - end of cooking programmable

Adjustable thermostat 120° - 500°F

Air cooled triple glazed removable door

#### True European convection

Oven capacity: 4.4 Cu Ft.

"Ever-Clean" enameled interior cavity

4 Shelf positions

2 x Halogen oven lights

Bake element 3.0kW

Broil element 2.9kW

Convection element 1.55kW

#### Gas Rangetop

5 gas burners

Right front 3,500 BTU

Right rear 6,500 BTU

Centre double inset brass super burner 18,000 BTU

Left front 10,000 BTU

Left rear 6,500 BTU

Heavy duty cast iron grates

Automatic electric ignition

LP Gas conversion kit included

#### Safety

Gas safety valves

Air cooled door to prevent overheating



Connected nominal power: 240 / 120V

Voltage rating: 240/120V 60Hz

Amp. supply required: 240 / 120V - 15A / 13.5A

Gas inlet location: back top right

**Accessories included:**

1 wok ring

1 moka ring

1 rotisserie kit

2 baking trays

2 chrome shelves

**Options:**

Island trim

## Functions

---



Main Oven

## Options

---

- **KITITR90X** - Island trim stainless steel
- **KIT1TR9X** - Backspalsh stainless steel

## Versions

---

- **TRU90BL** - Glossy Black Enamel
- **TRU90P** - Cream



## Main Oven



### Bottom heat:



This function is ideal for foods that require extra base temperature without browning, e.g. pastry dishes, pizza. Also suitable for slow cooking of stews and casseroles.



### Top and bottom heat:



This method is known as "conventional" cooking, and is suitable for dishes that require a more gentle heat, such as baking. The oven needs to be pre-heated to the required temperature, and is best suited for single items, such as large cakes. Best results are obtained by placing food in the centre of the oven.



### Convection with top and bottom heat:



The elements combined with the fan aim to provide more uniform heat. This is a similar method to conventional cooking, so pre-heat is required. This is not as effective as European convection cooking but can be used to cook biscuits and pastry.



### European convection:



The combination of the fan and circular element around it, gives uniform heat distribution with no cold spots. This has benefits - no preheat if cook time is more than 20 minutes, no flavour transfer when cooking different foods the same time, less energy is needed, and it cooks at 10% quicker than a normal oven.



### Convection broil:



Please note: cooking in this mode is conducted with the door closed. The fan reduces the fierce heat from the broiler, providing an excellent method for broiling a range of foods; chops, steaks, sausages etc. without having to turn the food during cooking. This gives good results, reduces drying out of foods, and gives even browning and heat distribution, the top two racks being recommended for use. The lower area of the cavity can also be used to keep other items warm at the same time.



### Intensive broil:



This allows rapid cooking and browning of foods. Best results can be obtained from using the top rack for small items, the lower racks for larger items, such as chops or sausages. Cooking using this method should be carried out with the door closed, unless instructed to do otherwise.



### Rotisserie with broil:



The rotisserie (where installed) works in combination with the broil element to brown foods to perfection.



### Defrost:



The circulation of air at room temperature enables quicker thawing of frozen food, (without the use of any heat). Ideal for use prior to cooking of readymade dishes, or cream filled products etc.



# TRU90X

Victoria



36"  
stainless steel  
cooktops type: gas  
oven type: electric multifunction

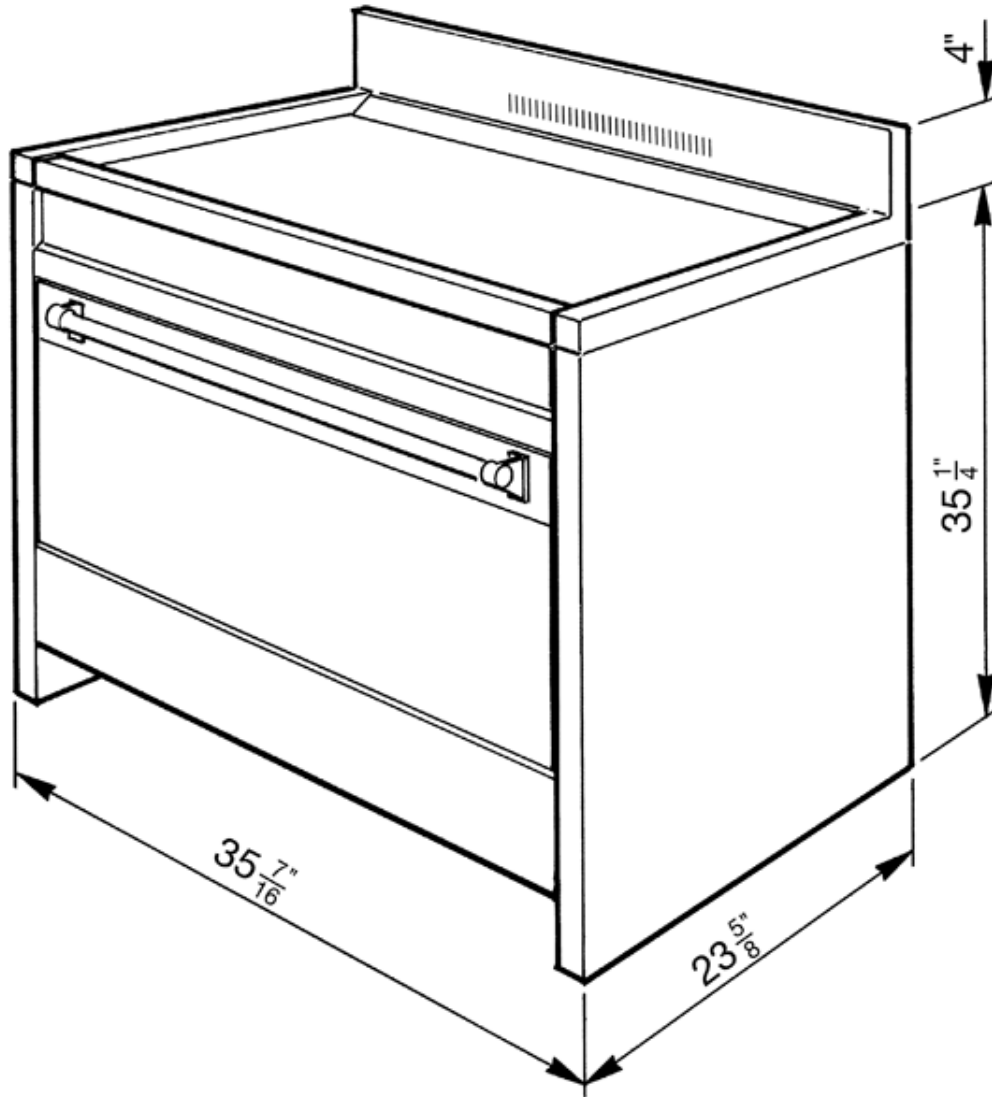

SMEG U.S.A. INC.  
A&D BUILDING  
150 EAST 58th STREET, 7th FLOOR  
NEW YORK, NY, 10155  
Tel. +1 212 265 5378  
Fax +1 212 265 5945