



CPF48UGMOR New product

Portofino

Portofino Pro-Style Dual Fuel Range,
Orange, 48" x 25"

EAN13: 8017709266738

PORTOFINO STYLE

Stainless steel control knobs

Thermoseal cavity, energy efficiency best-in-class

Soft close oven door

Full-width continuous grates

Storage compartment with inner drawer

MULTIFUNCTION ELECTRIC OVEN:

10 cooking modes including Pizza Function

Vapor-clean function

Programmable timer with touch display

Adjustable thermostat 120° - 500°F

Air-cooled triple-glazed removable door

Removable inner glass for easy cleaning

True European triple convection

Oven capacity: 4.5 cu. ft.

Ever Clean enameled interior cavity

5 shelf positions

2 x halogen oven lights

Bake element 1.7kW

Broil element 2.9kW

Convection element 1.5kW/element

MULTIFUNCTION ELECTRIC OVEN – SECONDARY OVEN

4 cooking modes

True European convection

Adjustable thermostat 120° - 440°F

"Ever-Clean" enameled oven interior

Air-cooled triple-glazed removable door

Removable inner glass for easy cleaning

Oven capacity: 1.45 Cu.Ft

5 shelf positions

2 x halogen oven lights

Bake element 750W

Broil element 2,05kW

Convection element 1.5kW

GAS RANGETOP:

5 gas burners with Electric Griddle

Center-rear 1200 BTU

Center-front 4500 BTU

Right-rear 12000 BTU

Right-front 8000 BTU

Left double-inset super burner 20000 BTU

Heavy-duty cast iron grates



Main Oven



Lower heating element only:

Ideal for foods that require extra base temperature without browning, e.g. pastry dishes, pizza. Also suitable for slow cooking of stews and casseroles. For Gas oven: Bake: traditional convection cooking.

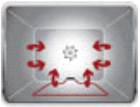

Convection:

This combination completes cooking more quickly of foods that are ready on the surface, but require more cooking inside, without further browning. For Gas Oven: Convection with lower elements: The fan is added to the gas burner to distribute the heat quickly and evenly throughout the oven cavity, avoiding flavour transfer when cooking a number of different dishes at the same time.



Bake:

Ideal for slow baked cakes and casseroles. This traditional static heat will ensure food remains moist when cooked for longer periods of time.



Convection Bake:

The elements combined with the fan aim to provide more uniform heat, a similar method to conventional cooking, so pre-heat is required. Most suitable for items requiring slow cooking methods.



European convection:

Hot air fan cooking that provides quick, multi layered cooking with excellent browning results. Due to the effective circulation of hot air, there is no flavour transfer between foods. Delicate and strongly fragranced foods can be cooked at the same time.



Convection broil:

The fan reduces the fierce heat from the broiler, providing an excellent method of grilling various foods, chops, steaks, sausages etc. giving even browning and heat distribution, without drying out the food. The top two levels recommended for use, and the lower part of the oven can be used to keep items warm at the same time, an excellent facility when cooking a grilled breakfast.



Half broiler:

For rapid cooking and browning of foods. Best results can be obtained by using the top shelf for small items, the lower shelves for larger ones, such as chops or sausages. For half grill heat is generated only at the centre of the element, so is ideal for smaller quantities.



Broiler:

For rapid cooking and browning of foods. Best results can be obtained by using the top shelf for small items, the lower shelves for larger ones, such as chops or sausages. For half grill heat is generated only at the centre of the element, so is ideal for smaller quantities.



Pizza function:

The simultaneous operation of these three elements ensures an optimum cooking facility, ideal not only for pizza but also for cookies, quiches and flans.



Rotisserie:

The rotisserie (where installed) works in combination with the broiler element whilst constantly turning the food.



Defrost at time:

Defrost at time

**Vapor Clean:**

a simple cleaning function using steam to loosen deposits in the oven cavity.

Secondary Oven

**Convection:**

This combination completes cooking more quickly of foods that are ready on the surface, but require more cooking inside, without further browning. For Gas Oven: Convection with lower elements: The fan is added to the gas burner to distribute the heat quickly and evenly throughout the oven cavity, avoiding flavour transfer when cooking a number of different dishes at the same time.

**European convection:**

Hot air fan cooking that provides quick, multi layered cooking with excellent browning results. Due to the effective circulation of hot air, there is no flavour transfer between foods. Delicate and strongly fragranced foods can be cooked at the same time.

**Convection broil:**

The fan reduces the fierce heat from the broiler, providing an excellent method of grilling various foods, chops, steaks, sausages etc. giving even browning and heat distribution, without drying out the food. The top two levels recommended for use, and the lower part of the oven can be used to keep items warm at the same time, an excellent facility when cooking a grilled breakfast.

**Broiler:**

For rapid cooking and browning of foods. Best results can be obtained by using the top shelf for small items, the lower shelves for larger ones, such as chops or sausages. For half grill heat is generated only at the centre of the element, so is ideal for smaller quantities.





CPF48UGMOR

Portofino

48"
orange
cooktops type: gas
oven type: electric multifunction

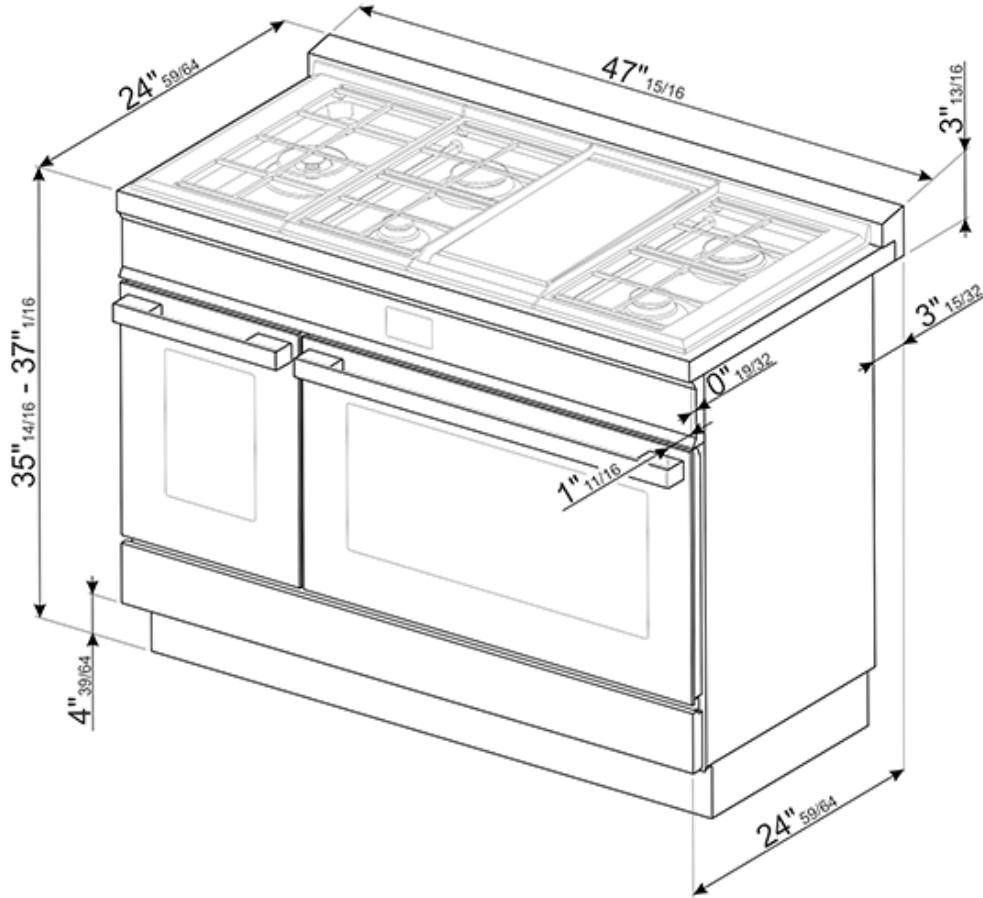

SMEG U.S.A. INC.
A&D BUILDING
150 EAST 58th STREET, 7th FLOOR
NEW YORK, NY, 10155
Tel. +1 212 265 5378
Fax +1 212 265 5945