



MI20XU Available soon

60CM (Approx 24") Built-in Microwave
Stainless Steel

EAN13: 8017709192730

Microwave with grill, multiple programs

Exclusive Classic Design

Fingerproof stainless steel

36 Automatic Programs including Memory and Slow cook

Automatic defrosting by time or weight

Stainless steel interior cavity

Lateral opening door

Single LED display

Quick Start Option

Control Lock / Child Safety

Natural Cooling system

9 ¾" Turntable

Microwave power: 800 W

Broil element: 900 W

20W internal light

Voltage rating 110V / 60Hz

Connected load (nominal power): 1280 W

Amps @ 110 V: 11

Accessories included:

Frame kit for built-in installation

1 Grid

For availability please contact Smeg USA



Functions



Main Oven

**SMEG U.S.A. INC.
A&D BUILDING
150 EAST 58th STREET, 7th FLOOR
NEW YORK, NY, 10155
Tel. +1 212 265 5378
Fax +1 212 265 5945**



Main Oven



Microwave:

Penetrating straight into the food, microwaves cook very quickly and with considerable energy savings. Suitable for cooking without fat, they are also able to thaw and heat food without altering its original appearance and aroma. The microwave function can also be combined with conventional functions with all the resulting advantages. Ideal for all types of food.



Defrost:

The circulation of air at room temperature enables quicker thawing of frozen food, (without the use of any heat). Ideal for use prior to cooking of readymade dishes, or cream filled products etc.



Microwave + broil element:

To achieve a combined cooking with broil that cooks the outside whilst assuring an internal cooking thanks to the microwave function.



Intensive broil:

This allows rapid cooking and browning of foods. Best results can be obtained from using the top rack for small items, the lower racks for larger items, such as chops or sausages. Cooking using this method should be carried out with the door closed, unless instructed to do otherwise.



MI20XU

microwave
24"
stainless steel

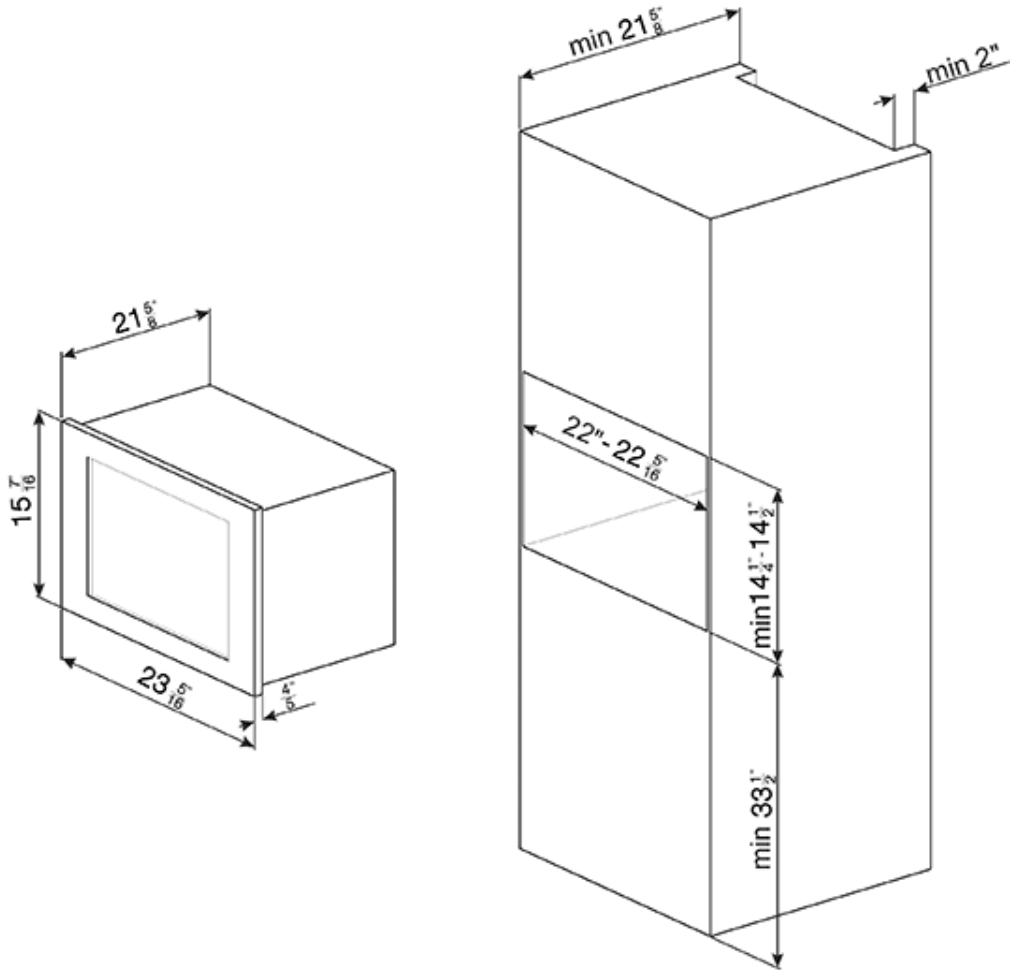

SMEG U.S.A. INC.
A&D BUILDING
150 EAST 58th STREET, 7th FLOOR
NEW YORK, NY, 10155
Tel. +1 212 265 5378
Fax +1 212 265 5945