

FQ75XPEDU

36", Stainless Steel, 4-doors Refrigerator with Automatic Freezer

EAN13: 8017709215736

Standard hinge

Fingerprint-proof

Display: LCD

Display functions: holiday, fast freezing, fast cooling, multizone, energy efficiency mode, child safety lock, ajar door alarm

Adaptable compartment(freezer or refrigerator space)

Ice & water dispenser

Refrigerator compartment features:

Glass adjustable shelves

Crisper compartment

LED refrigerator internal lighting

Refrigerator inner door:

1 balcony with transparent cover

5 adjustable balconies

2 bottle balconies

1 egg tray

Natural Plus Blue light

Freezer compartment features:

4 drawers

2 glass shelves

Other freezer features:

Fast-freezing compartment

Fast-freezing button

Performance/energy label:

Annual energy consumption: 681 kWh

Fresh food compartment net volume: 15.37 cu. ft.

Freezer compartment net volume: 7.35 cu. ft.

Frozen food compartment star rating: 4

Frost-free system

Freezing capacity: 13kg/h

Climatic class: T

Noise level: 47dB(A)

Electrical connection:

Voltage: 120V

Frequency (Hz): 60Hz

Plug type: USA

With door opened to 90°: 113 cm (including handle) 44 ½"

Dimensions: HxWxD 185x91x86cm
72 4/5 x 35 4/5 x 33 9/10"



Functions



**SMEG U.S.A. INC.
A&D BUILDING
150 EAST 58th STREET, 7th FLOOR
NEW YORK, NY, 10155
Tel. +1 212 265 5378
Fax +1 212 265 5945**



FQ75XPEDU

fridge
free standing
4 doors
stainless steel
36"



Energy Star and ISO14001 Certified:

The Smeg production process is carefully managed in order to keep the impact upon the environment as low as possible. The process is checked and certified by Independent International bodies IQNET and CISQ (Smeg complies with the standard ISO14001). All Smeg dishwashers are ENERGY STAR qualified. Energy efficiency is important to Smeg and our technicians are constantly working to keep the energy, and water, consumption of each dishwasher as low as possible. ENERGY STAR certified products use less water than conventional dishwashers, and approximately 40% less energy than the federal minimum standard for energy consumption. By choosing an ENERGY STAR certified product you are helping to preserve the environment without compromising on product quality or performance.



SMEG U.S.A. INC.
A&D BUILDING
150 EAST 58th STREET, 7th FLOOR
NEW YORK, NY, 10155
Tel. +1 212 265 5378
Fax +1 212 265 5945



FQ75XPEDU

fridge
free standing
4 doors
stainless steel
36"

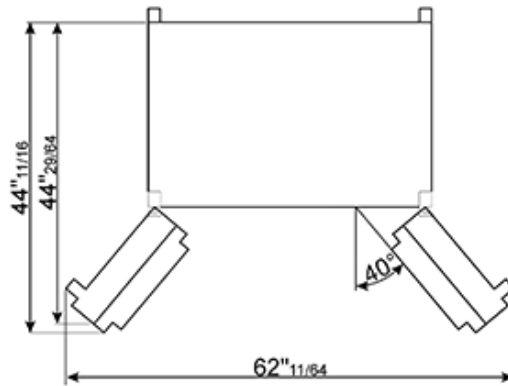
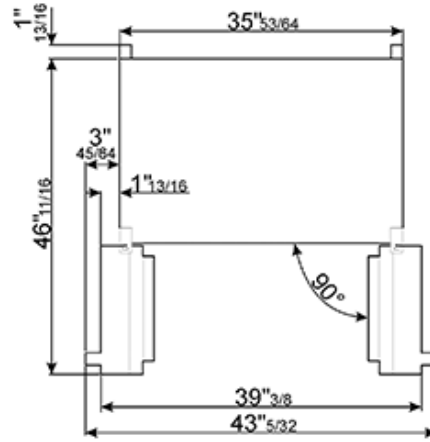
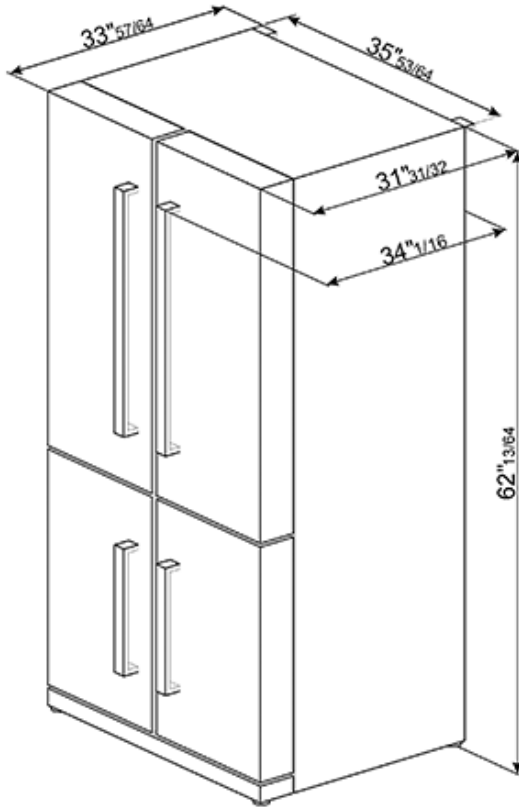

SMEG U.S.A. INC.
A&D BUILDING
150 EAST 58th STREET, 7th FLOOR
NEW YORK, NY, 10155
Tel. +1 212 265 5378
Fax +1 212 265 5945