

## S2951CXU

90CM (approx. 36") Ceramic  
Cooktop  
Stainless Steel Frame

EAN13: 8017709113605

5 High-Light radiant zones:

Front right: 1,200 W -  $\varnothing$  5 1/2" (140mm)

Back right: 2,000 W -  $\varnothing$  7 5/8" (195mm)

Central: 750 + 900 + 1,050 W -  $\varnothing$  5 1/2" - 8 1/4" - 10 5/8"  
(140-210-270mm)

Front left: 800 + 1,200 W -  $\varnothing$  4 3/4" - 7" (120-180mm)

Back left: 1,200 W -  $\varnothing$  5 1/2" (140mm)

Elegant stainless steel frame

"Suprema" black ecological glass

Soft touch controls

5 high-light radiant elements, including 2 variable zones (central high speed zone with three level adjustment)

9 power levels for each zone

Residual heat indicator for each zone

Automatic safety cut-out

Individual timer for each zone (1 - 99min)

Safety lock device

Voltage rating: 240/208V - 60Hz

Connected load (nominal power): 240/208V-  
8.6/6.5kW

Amps @ 240/208V: 36/32

Electrical - single phase 3 or 4 wire cable required,  
120/240V or 120/208V, 60Hz, fused on both sides  
of  
line with ground.

Accessories Included:

1 Cleaning scraper





# S2951CXU

ceramic cooktop  
36"  
black  
touch control

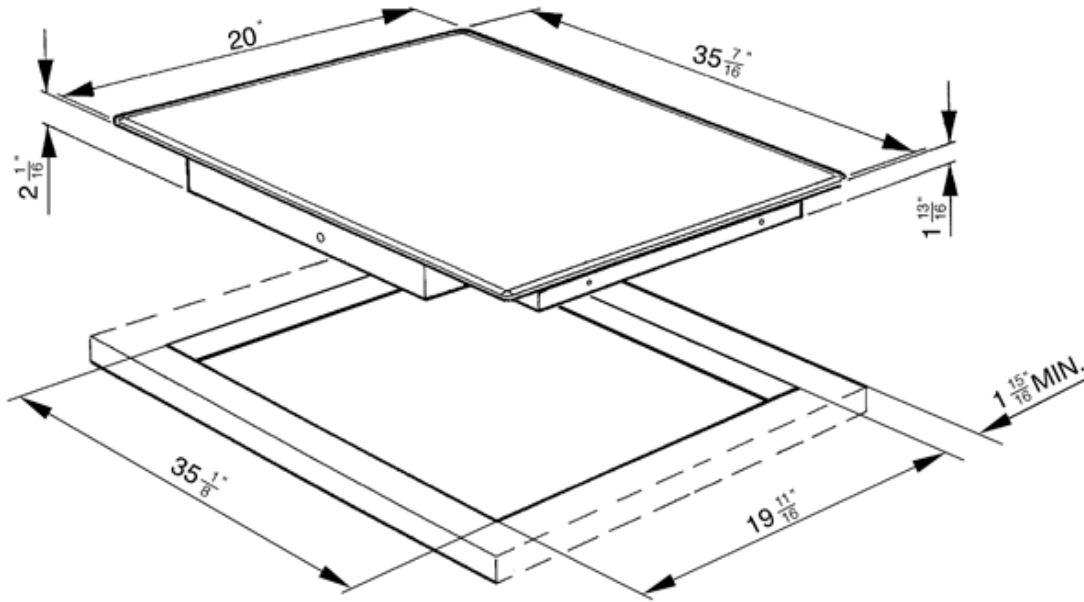

SMEG U.S.A. INC.  
A&D BUILDING  
150 EAST 58th STREET, 7th FLOOR  
NEW YORK, NY, 10155  
Tel. +1 212 265 5378  
Fax +1 212 265 5945