

S2951CXU

90CM (approx. 36") Ceramic
Cooktop
Stainless Steel Frame

EAN13: 8017709113605

5 High-Light radiant zones:

Front right: \varnothing 5 1/2" (140mm) - Booster 1,200 W

Back right: \varnothing 7 5/8" (195mm) - Booster 2,000 W

Central: \varnothing 5 1/2" - 8 1/4" - 10 5/8" (140-210-270mm) -
Booster 750 + 900 + 1,050 W

Front left: \varnothing 4 3/4" - 7" (120-180mm) - Booster 800 +
1,200 W

Back left: \varnothing 5 1/2" (140mm) - Booster 1,200 W

Elegant stainless steel frame

Soft touch controls

5 high-light radiant elements, including 2 variable
zones (central high speed zone with three level
adjustment)

9 power levels for each zone

Residual heat indicator for each zone

Automatic safety cut-out

Individual timer for each zone (1 - 99min)

Child safety lock

Voltage rating: 240/208V - 60Hz

Connected load (nominal power): 240/208V -
8.6/6.5kW

Amps 240/208V: 36/32 Amps

Electrical - single phase 3 or 4 wire cable required,
120/240V or 120/208V, 60Hz, fused on both sides
of
line with ground.

Accessories Included:

1 Cleaning scraper





S2951CXU

ceramic cooktop
36"
black
touch control

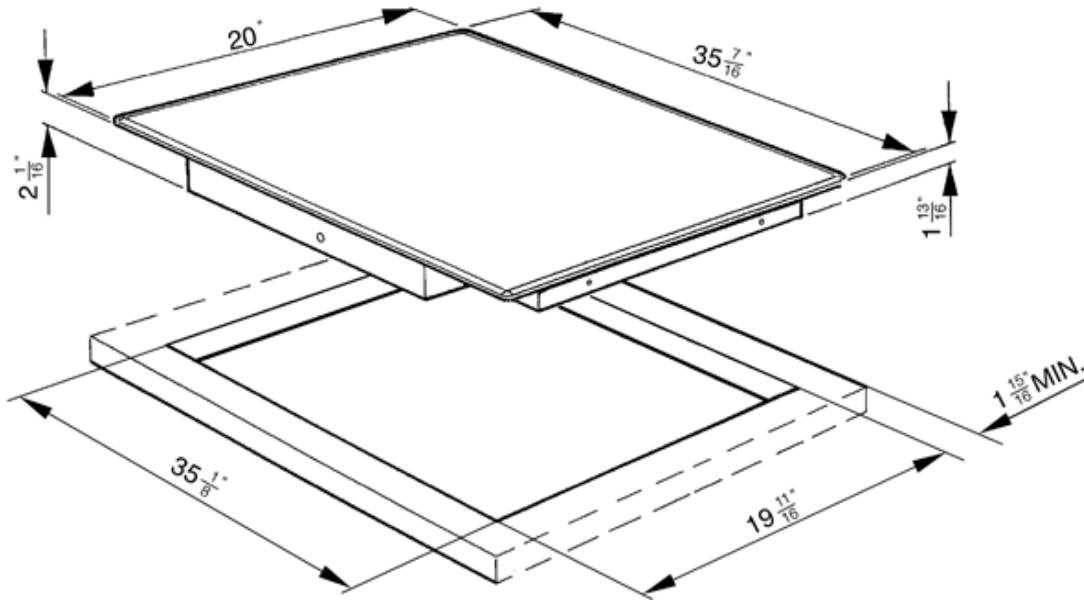

SMEG U.S.A. INC.
A&D BUILDING
150 EAST 58th STREET, 7th FLOOR
NEW YORK, NY, 10155
Tel. +1 212 265 5378
Fax +1 212 265 5945