

90CM (approx. 36") Ceramic Cooktop  
Stainless Steel Frame  
EAN13: 8017709113605

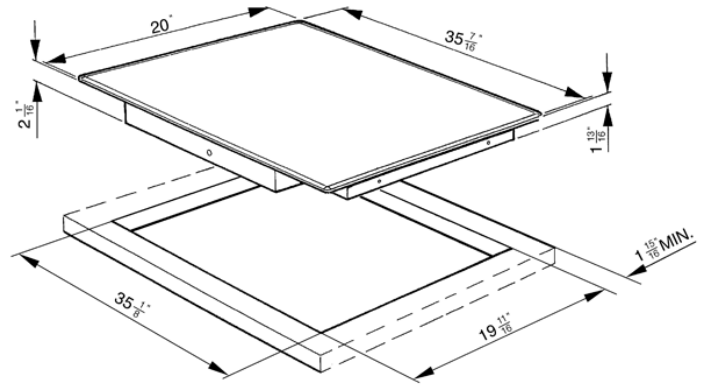

- 5 High-Light radiant zones: • Front right: 1,200 W -  $\varnothing$  5 1/2" (140mm) • Back right: 2,000 W -  $\varnothing$  7 5/8" (195mm) • Central: 750 + 900 + 1,050 W -  $\varnothing$  5 1/2" - 8 1/4" - 10 5/8" (140-210-270mm) • Front left: 800 + 1,200 W -  $\varnothing$  4 3/4" - 7" (120-180mm) • Back left: 1,200 W -  $\varnothing$  5 1/2" (140mm) •
- Elegant stainless steel frame • "Suprema" black ecological glass • Soft touch controls • 5 high-light radiant elements, including 2 variable zones (central high speed zone with three level adjustment) • 9 power levels for each zone • Residual heat indicator for each zone • Automatic safety cut-out • Individual timer for each zone (1 - 99min) • Safety lock device • Voltage rating: 240/208V - 60Hz • Connected load (nominal power): 240/208V-8.6/6.5kW • Amps @ 240/208V: 36/32 • Electrical - single phase 3 or 4 wire cable required, 120/240V or 120/208V, 60Hz, fused on both sides of line with ground. • Accessories Included: • 1 Cleaning scraper