

PRD486GDHU 48-INCH DUAL-FUEL PRO HARMONY® RANGE WITH GRIDDLE

PROFESSIONAL SERIES, STANDARD-DEPTH, PORCELAIN COOKTOP SURFACE



GENERAL PROPERTIES

Oven Capacity	4.3 / 2.2 cu. ft.
Cooking Modes - Main / Large Cavity	
Bake, Convection Bake, Broil, Convection Broil, Self Clean, Warm, Extended Bake	
Cooking Modes - Small Cavity	
Bake, Convection Bake, Broil, Convection Broil, Self Clean, Warm, Extended Bake	
Programs	Sabbath Function
Cleaning Type	Self Clean (Both)
Type of Grate	Continuous Cast Iron
Controls	Metal Knobs
Sealed Burners	Yes

OVEN PERFORMANCE

Bake Power	2,400 W (Lg) / 1,400 W (Sm)
Broil Power	4,000 W (Lg) / 2,600 W (Sm)
Convection Power	2,750 W Ring (Lg)

BURNER PERFORMANCE

Total Number of Cooktop Burners	6 + Griddle
Total Cooktop BTU	108,000 (NG)
Power of Front Left Burner BTU	18,000-3,000 XLO (NG)
Power of Back Left Burner BTU	18,000-3,000 XLO (NG)
Power of Back Center Burner BTU	18,000 (NG)
Power of Front Center Burner BTU	18,000 (NG)
Power of Center 12" Electric Griddle (W)	1,630 W
Power of Center 12" Electric Grill (W)	N/A
Power of Far Right 12" Electric Griddle (W)	N/A
Power of Back Right Burner BTU	18,000 (NG)
Power of Front Right Burner BTU	18,000 (NG)

DIMENSIONS & WEIGHT

Overall Appliance Dimensions (HxWxD) (in)	35 7/8"–36 3/4" x 47 7/8" x 24 3/4"
Required Cutout Size (HxWxD) (in)	35 7/8"–36 3/4" x 48" x 24"
Adjustable Range Height (in.)	7/8"
Net Weight (lbs)	560 lbs

ACCESSORIES (INCLUDED)

1 X Island Trim, 3 X Full Access Telescopic Racks, 2 X Telescopic Rack - Small, 1 X Broiler Pan

WARRANTY

Limited Warranty, Entire Appliance, Parts and Labor	2 Year
---	--------

FEATURES & BENEFITS

- ★ - Exclusive, patented Star® Burner—most even heating, unsurpassed flame coverage
- ★ - QuickClean Base® designed for easy surface cleaning
- ★ - Precision simmering capabilities as low as 100°F (375 BTU) with 2 ExtraLow® Simmer burners
- ★ - Cleans both ovens simultaneously in just 2 hours
 - Professional style, continuous cast iron grates

TECHNICAL DETAILS

Circuit Breaker (A)	50 A
Volts (V)	240 / 208 V
Frequency (Hz)	60 Hz
Plug Type	No Plug
Power Cord Length (in)	Purchase Separately
Energy Source	Gas and Electric
Gas Type	Natural Gas 15 mbar (USA)
Alternative Gas Type	Liquid Gas 27.5 mbar (USA)

SEE PAGE 2 FOR OPTIONAL ACCESSORIES

PRD486GDHU 48-INCH DUAL-FUEL PRO HARMONY® RANGE WITH GRIDDLE



PROFESSIONAL SERIES, STANDARD-DEPTH, PORCELAIN COOKTOP SURFACE

ACCESSORIES (OPTIONAL)

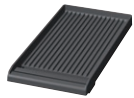

PA12GRILLN
Pro Grill

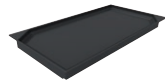

PAGRIDDLEN
Griddle for Indoor
Electric Grill



PA12CVRJ
12" Pro Grill / Griddle
Cover



PA12CHPBLK
12" Cutting Board



PWOKRINGHC
Wok Ring



PA48GLBH
9" Low Backguard



PAKNOBLUNH
Blue Knob Pro Harmony Kit



PALPKITHN
LP Conversion Kit



PAGRIDDLE
Griddle

48-INCH RANGE DIMENSIONS

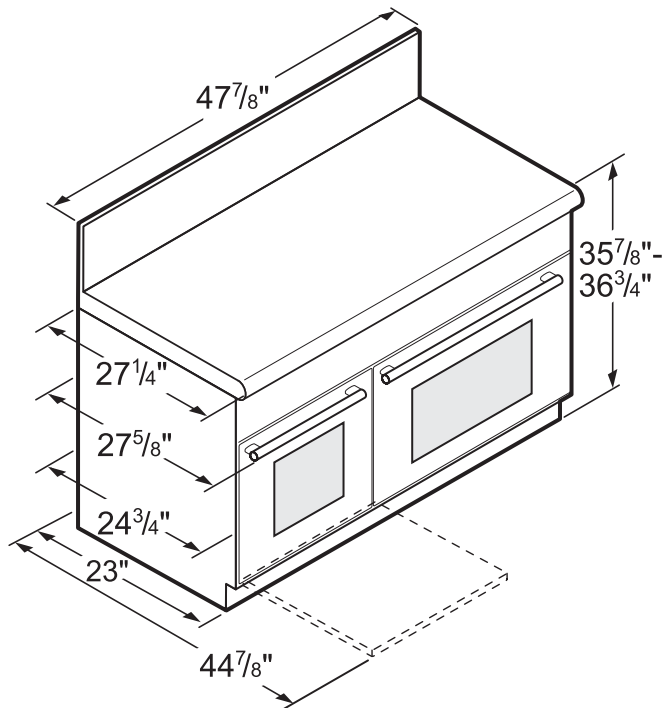

48-INCH RANGE CUTOUT DIMENSIONS

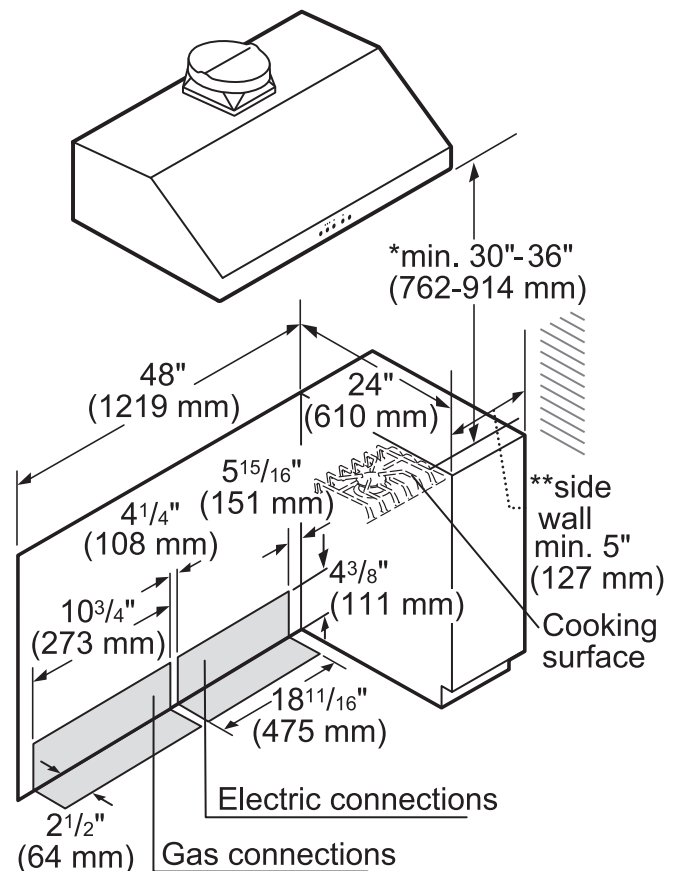

* 30" (762 mm) minimum clearance above cooking surface to non-combustible surface. Minimum clearance above cooking surface to combustible surface is 36" (914 mm).

** 5" (127 mm) minimum clearance from sides of the cooker, above the cooking surface, to combustible side walls.

Note: Most hoods contain combustible components that must be considered when planning the installation.

measurements in inches

PRD486GDHU 48-INCH DUAL-FUEL PRO HARMONY® RANGE WITH GRIDDLE



PROFESSIONAL SERIES, STANDARD-DEPTH, PORCELAIN COOKTOP SURFACE

48-INCH RANGE CUTOUT DIMENSIONS

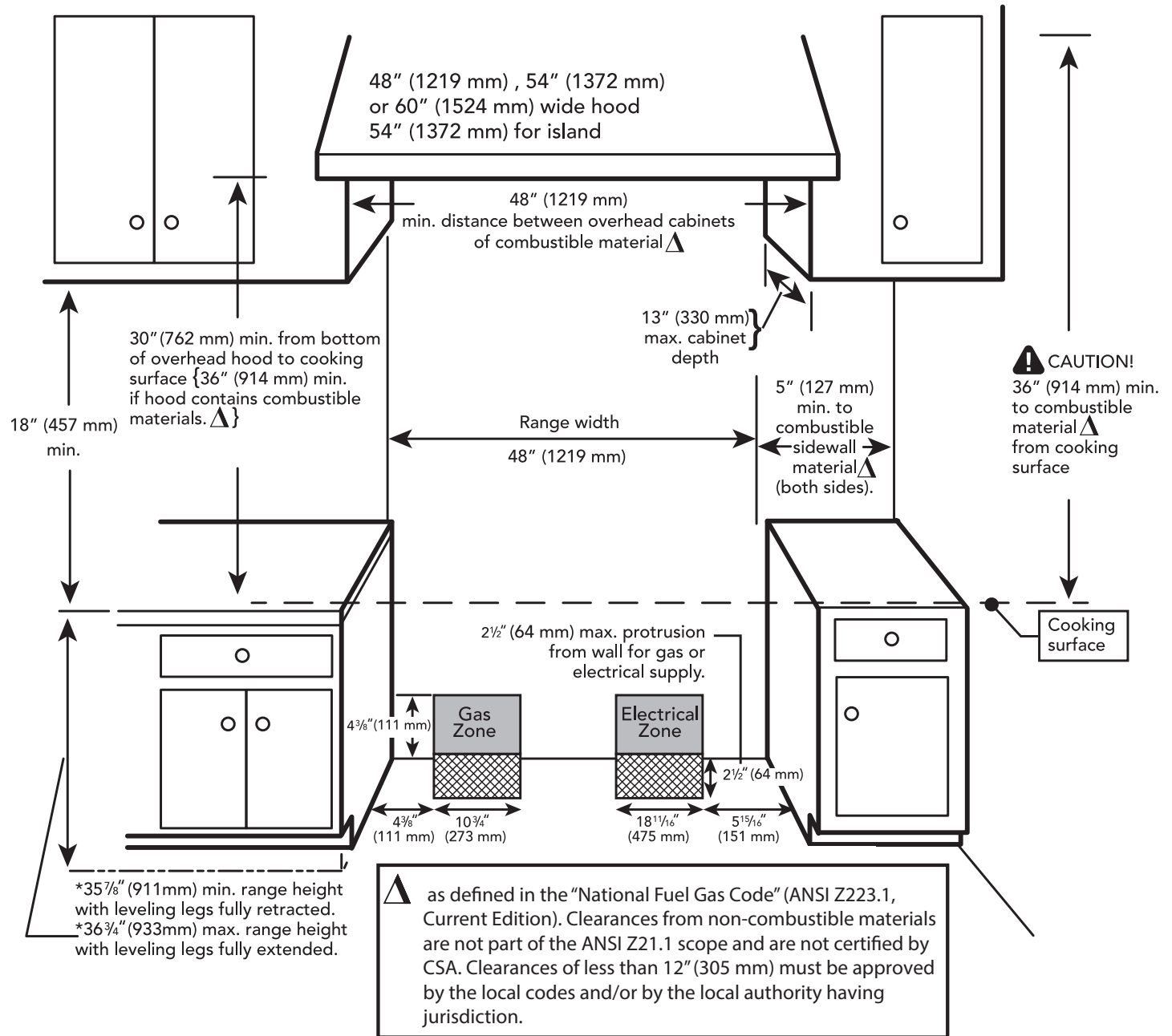

PRD486GDHU 48-INCH DUAL-FUEL PRO HARMONY® RANGE WITH GRIDDLE



PROFESSIONAL SERIES, STANDARD-DEPTH, PORCELAIN COOKTOP SURFACE

48-INCH RANGE DIMENSIONS AND CLEARANCE REQUIREMENTS WITH "LOW BACK"

NOTE: A 36-inch minimum clearance is required between the top of the cooking surface and the bottom of an unprotected cabinet. A 30-inch clearance can be used when the bottom of the wood or metal cabinet is protected by not less than 1/4 inch of a flame retardant material covered with not less than No. 28 MSG sheet steel, 0.015 inch (0.4 mm) thick stainless steel, 0.024 inch (0.6 mm) aluminum, or 0.020 inch (0.5 mm) thick copper.

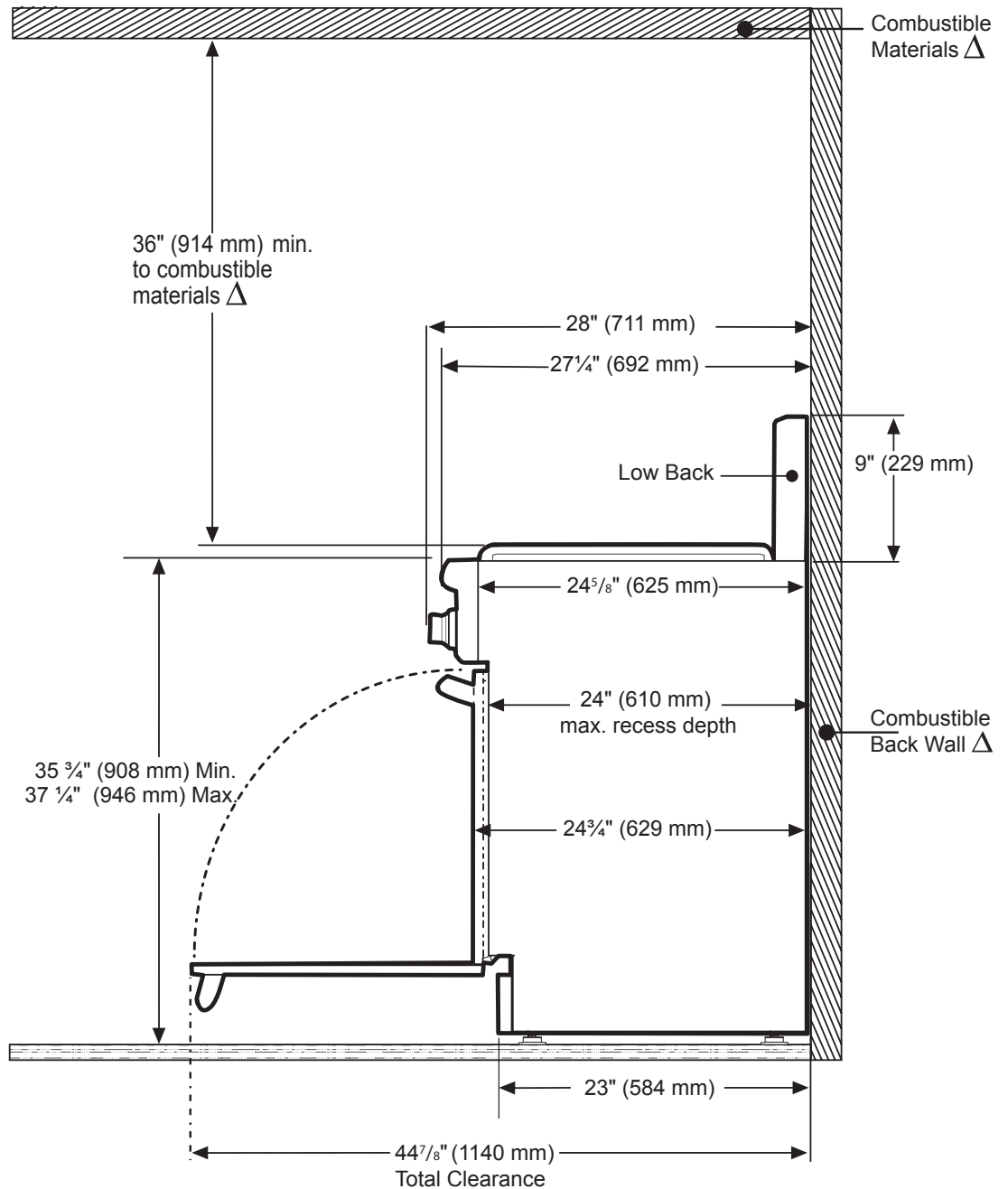

△ As defined in the "National Fuel Gas Code" (ANSI Z223.1, Current Edition). Clearances from non-combustible materials are not part of the ANSI Z21.1 scope and are not certified by CSA. Clearances of less than 12" (305 mm) must be approved by the local codes and/or by the local authority having jurisdiction.

PRD486GDHU 48-INCH DUAL-FUEL PRO HARMONY® RANGE WITH GRIDDLE

PROFESSIONAL SERIES, STANDARD-DEPTH, PORCELAIN COOKTOP SURFACE



48-INCH RANGE DIMENSIONS AND CLEARANCE REQUIREMENTS WITH "FLUSH ISLAND TRIM"

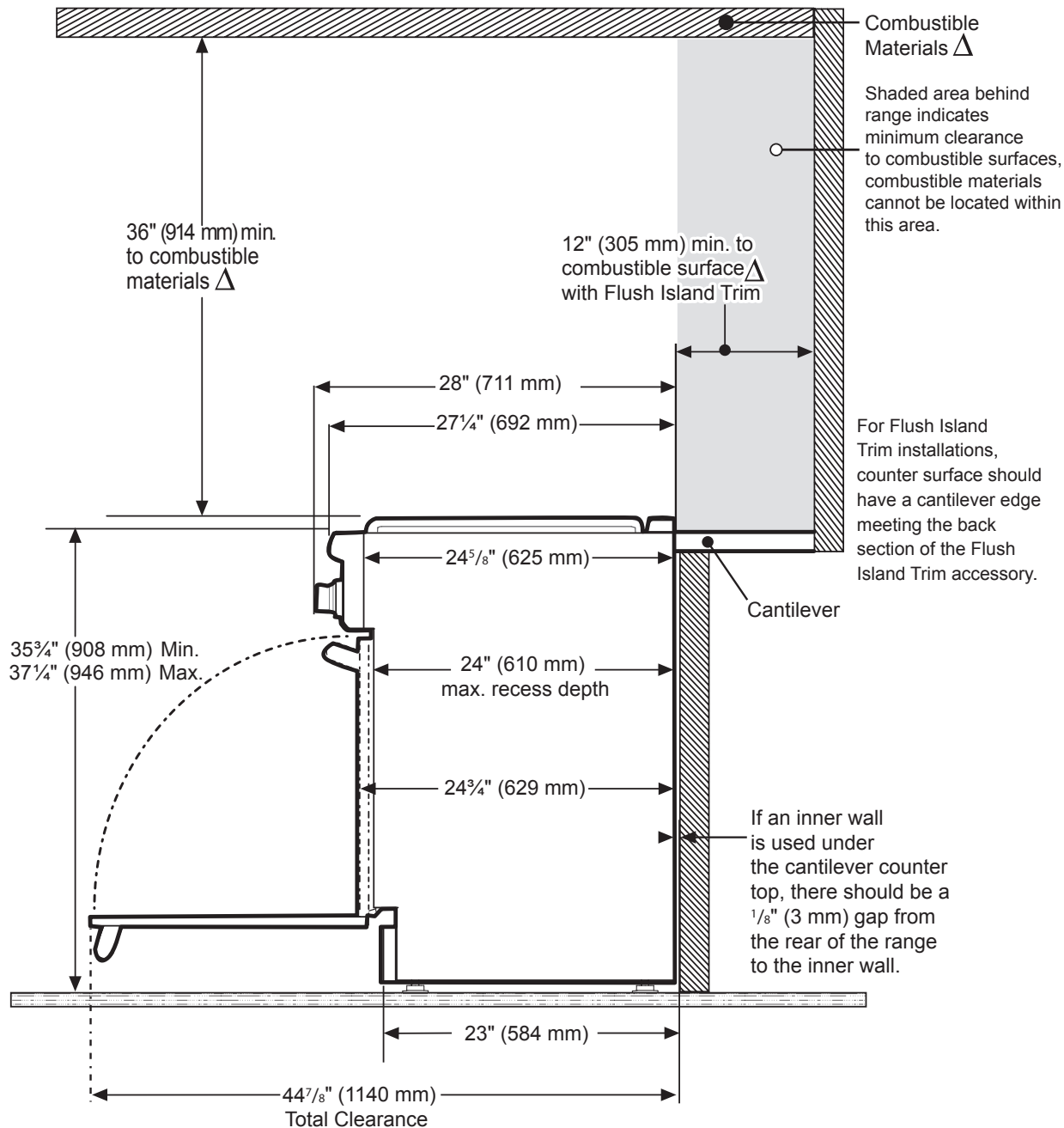

△ As defined in the "National Fuel Gas Code" (ANSI Z223.1, Current Edition). Clearances from non-combustible materials are not part of the ANSI Z21.1 scope and are not certified by CSA. Clearances of less than 12" (305 mm) must be approved by the local codes and/or by the local authority having jurisdiction.

These warranties give you specific legal rights and you may have other rights that vary from state to state. Full warranty and limited warranty from date of installation. For complete warranty details, refer to your Use & Care manual, or ask your dealer.

Specifications are for planning purposes only. Refer to installation instructions and consult your countertop supplier prior to making counter opening. Consult with a heating and ventilation engineer for your specific ventilation requirements. For the most detailed information, refer to installation instructions accompanying product or write to Thermador indicating the model number. Specifications are correct at time of printing. Thermador reserves the right to change product specifications or design without notice. Some models are certified for use in Canada. Thermador is not responsible for products that are transported from the U.S. for use in Canada.