

# 48" Professional Series Pro Grand Commercial Depth Dual Fuel Steam Range PRD48JDSGC



## PRD48JDSGC Stainless steel

### INNOVATION

- The only range in the market with a steam and convection combination oven, plus a full-size convection oven and a warming drawer
- 27 Easy Cook® food programs. Pre-programmed modes automatically set the oven temperature and humidity to ensure perfect cooking results
- Patented Pedestal Star® Burner with QuickClean Base® designed for easy surface cleaning and superior heat spread for any size pan
- Powerful 22,000 BTU (NG) burner (front right)
- Precision simmering capabilities as low as 100°F (375 BTU) with 4 ExtraLow® Simmer burners
- SoftClose® hinges for ultra smooth closing of both ovens and the warming drawer.
- Glass surface warming drawer

### PERFORMANCE

- 18,000 BTU (NG) Star® Burners
- Titanium surface non-stick, rust-proof cast-aluminum griddle and grill, removable for easy clean-up
- 1.4 cu.ft. steam cavity easily accommodates a 14lb. Turkey
- Steam oven features 9 advanced conventional cooking modes
- Steam cavity is non-plumbed, for easy installation into any home
- Steam Clean function helps keep the steam oven spotless
- Electronic oven display interfaces to cook timer, CookControl™ meat probe and preheat status with audible alert
- Third Element Convection offers precise airflow for cooking on multiple levels without flavor transfer
- Powerful, 4000 Watt 8-pass broil elements in large oven
- Full Access® telescopic racks, integrated easy-grip handle
- Spacious 1.1 cu. ft. warming drawer holds up to ten 11" dinner plates
- Drawer has open sides for easy and convenient access
- Star-K Kosher certified

### DESIGN

- Distinctive three door design showcases Thermador's self-assured bold and elegant design
- Pinhole and panel lighting concepts provide functional and

# 48" Professional Series Pro Grand Commercial Depth Dual Fuel Steam Range PRD48JDSCG

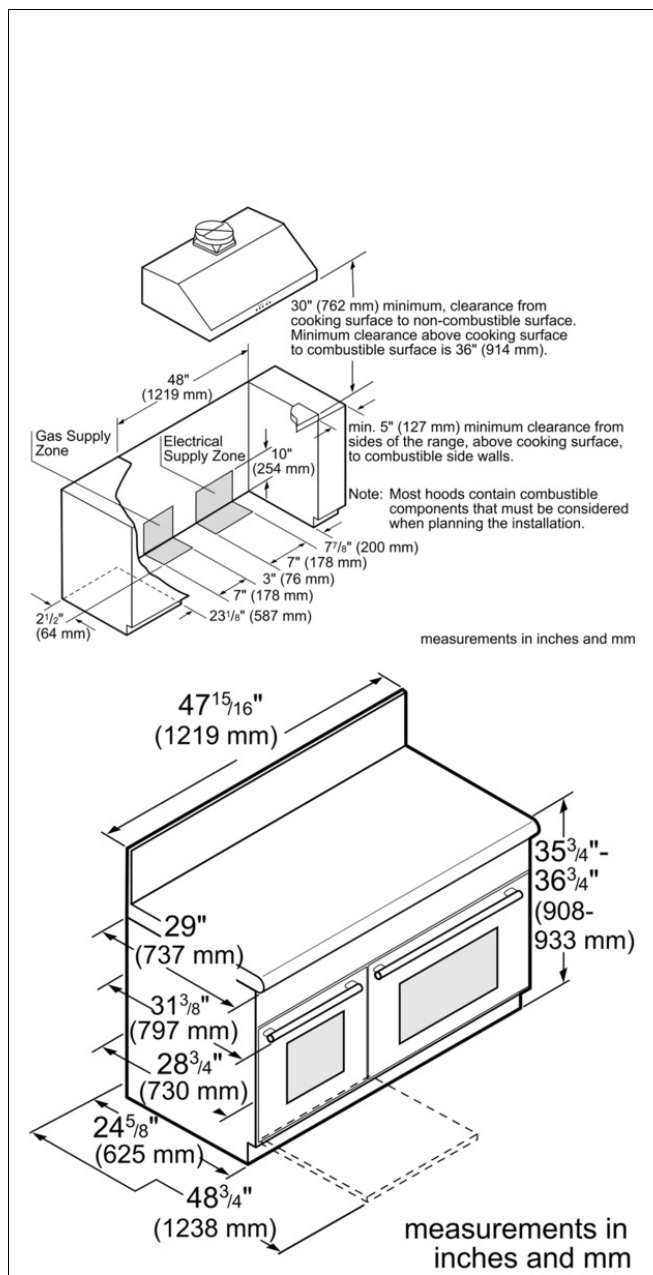

## Product Features

- Construction type: Freestanding
- Product color: Stainless steel
- Power cord length (cm): 137.0
- Net weight (kg): 229.000
- Gross weight (kg): 254.000

## Consumption and connection features

- Energy consumption conventional (kWh) - cavity 1:
- Energy consumption forced air convection (kWh) - cavity 1:
- Watts (W): 40580
- Current (A): 50
- Volts (V): 240/208
- Frequency (Hz): 60
- Plug type: 240V-4 prong

2013-07-12