

# 48" Professional Series Pro Grand Commercial Depth All Gas Range

## PRG486JDG



### PRG486JDG Stainless steel

#### INNOVATION

- Powerful 22,000 BTU (NG) burner (front right)
- 18,000 BTU (NG) Star® Burners
- Precision simmering capabilities as low as 100°F (375 BTU) with 4 ExtraLow® Simmer burners
- SoftClose™ hydraulic hinge. Ultra smooth closing on both oven doors. Thermador exclusive feature
- Full featured small oven with convection, broil, self clean and CookControl™ meat probe
- Superfast 2 hour self clean in both ovens
- Full Access® telescopic racks, integrated easy-grip handle

#### PERFORMANCE

- Titanium surface non-stick, rust-proof cast-aluminum griddle and grill, removable for easy clean-up
- Electronic oven display interfaces to cook timer, CookControl™ meat probe and preheat status with audible alert
- Powerful, 30,000 BTU bake and 17,000 BTU broil burners in the large oven, 15,000 BTU bake and 9,000 broil in the small
- Convection Bake offers precise multi-level baking results
- Large oven 5.5 cu.ft.-accommodates commercial sheet pan plus 2.4 cu.ft. in small oven
- Six rack levels in each oven for multiple item cooking
- Star-K Kosher certified

#### DESIGN

- Bold Professional design
- Pinhole and panel lighting concepts provide functional and stylish aesthetics
- Restaurant style metal knobs
- Professional style, continuous cast iron grates
- Continuous porcelain, easy to clean cooking surface
- Large oven door window for maximum viewing
- Powerful halogen lighting illuminates the oven cavity
- Signature blue indicator lighting
- Patented Pedestal Star® Burner with QuickClean Base® designed for easy surface cleaning and superior heat spread for any size pan

#### Optional accessories

- PA12CVRJ 12" Professional Griddle Cover Accessory
- PA12GRILHC 12" Grill Accessory

# 48" Professional Series Pro Grand Commercial Depth All Gas Range

## PRG486JDG

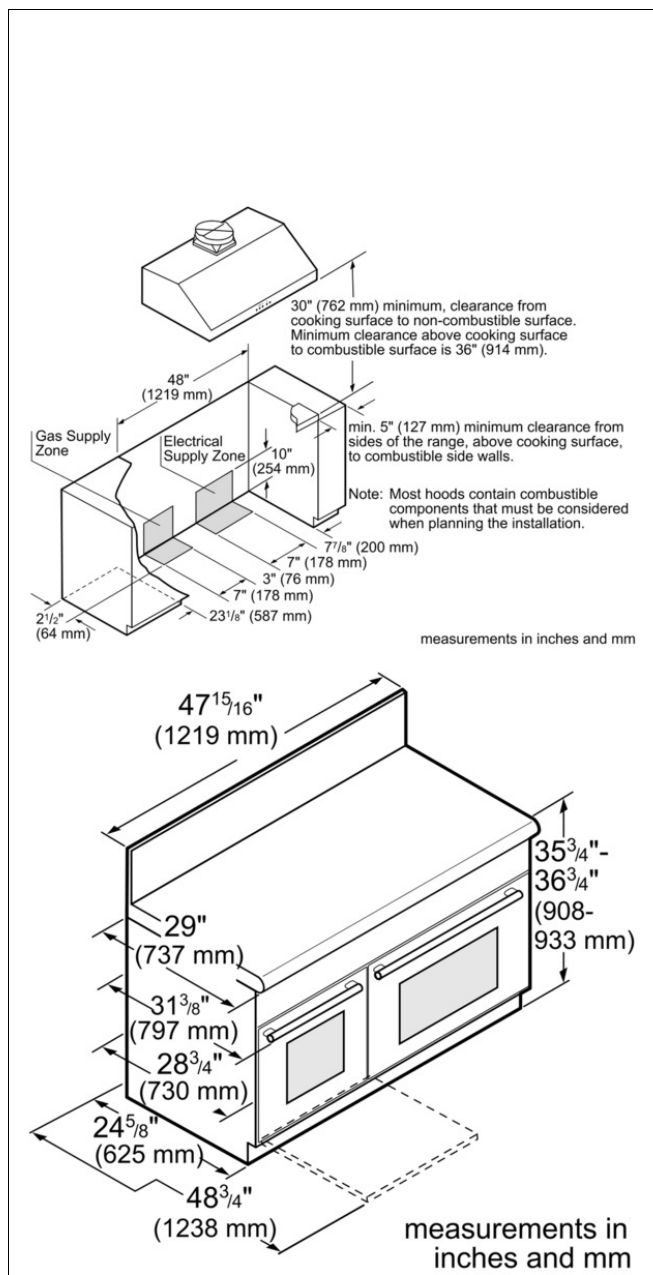

### Product Features

- Construction type: Freestanding
- Product color: Stainless steel
- Power cord length (cm): 168.0
- Net weight (kg): 237.000
- Gross weight (kg): 263.000

### Consumption and connection features

- Energy consumption conventional (kWh) - cavity 1:
- Energy consumption forced air convection (kWh) - cavity 1:
- Watts (W):
- Current (A): 20
- Volts (V): 120
- Frequency (Hz): 60
- Plug type: 120V-3 prong

2013-07-12