

**THOR**  
K I T C H E N<sup>®</sup>

# USE + CARE MANUAL

---

**15 INCH INDOOR OUTDOOR  
ICE MAKER**  
TIM1511

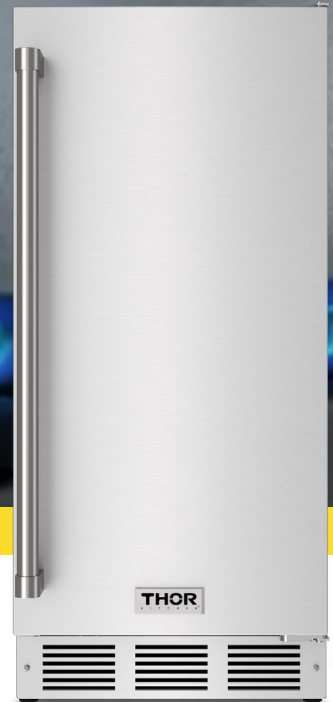

## IMPORTANT SAFETY INSTRUCTIONS

### WARNING

#### California Proposition 65

Certain components in this product and its related accessories contain chemicals known to the state of California to cause cancer, birth defects or other reproductive harm.



**DANGER – Risk Of Fire Or Explosion. FLAMMABLE REFRIGERANT Used. Do Not Use Mechanical Devices To Defrost Refrigerator. Do Not Puncture Refrigerant Tubing.**

**DANGER – Risk Of Fire Or Explosion. FLAMMABLE REFRIGERANT Used. To Be Repaired Only By Trained Service Personnel. Do Not Puncture Refrigerant Tubing.**

**CAUTION – Risk Of Fire Or Explosion. FLAMMABLE REFRIGERANT Used. Consult Repair Manual/Owner's Guide Before Attempting To Service This Product. All Safety Precautions Must be Followed.**

**CAUTION – Risk Of Fire Or Explosion. Dispose Of Properly In Accordance With The Applicable Federal Or Local Regulations. FLAMMABLE REFRIGERANT Used.**

**CAUTION – Risk Of Fire Or Explosion Due To Puncture Of Refrigerant Tubing; Follow Handling Instructions Carefully. FLAMMABLE REFRIGERANT Used.**

– **WARNING: Keep ventilation openings, in the appliance enclosure or in the built-in structure, clear of obstruction.**

– **WARNING: Do not use mechanical devices or other means to accelerate the defrosting process, other than those recommended by the manufacturer.**

– **WARNING: Do not damage the refrigerant circuit.**

– **WARNING: Do not operate electrical appliances inside the food storage compartments of this appliance, except for those specifically recommended by the manufacturer.**

#### DISPOSAL

The appliance cannot be treated as normal domestic trash but must be handed in at a collection point for recycling electric and electronic appliances. Your contribution to the correct disposal of this product protects the environment. Further information about the recycling of this product can be obtained from your local municipal authority.

*This appliance is intended to be used in household and similar applications such as*

- staff kitchen areas in shops, offices and other working environments;*
- farm houses and by clients in hotels, motels and other residential type environments;*
- bed and breakfast type environments;*
- catering and similar non-retail applications.*

**THE MANUFACTURER DISCLAIMS ANY RESPONSIBILITY IF THE ABOVE INSTRUCTIONS ARE NOT FOLLOWED.**

# TABLE OF CONTENTS

IMPORTANT SAFETY INSTRUCTIONS.....	1
SAFETY DEFINITIONS.....	3
SAFETY PRECAUTIONS.....	3
SPECIFICATION.....	5
OPERATING THE UNIT.....	6
INSTALLATION.....	7
BUILT-IN CABINET DIMENSIONS.....	8
CONNECTING THE WATER SUPPLY.....	8
FILTER INSTALLATION/REPLACEMENT.....	9
ELECTRICAL CONNECTION.....	10
LEVELING THE UNIT.....	11
REVERSING THE DOOR.....	12-13
USING THE CONTROLS.....	13-16
PANEL DISPLAY NOTIFICATION.....	16
FAULT ALARM AND ERROR CODES.....	16-17
MAINTENANCE.....	17
CLEANING AND MAINTAINING THE UNIT.....	17
CLEANING THE UNIT'S EXTERIOR.....	17
CLEANING THE UNIT'S INTERIOR.....	17
EXTENDED PERIODS OF NON-USE.....	18
TROUBLESHOOTING.....	19-20
WARRANTY.....	21

# SAFETY

## SAFETY DEFINITIONS

The words **DANGER**, **WARNING**, **CAUTION** and **NOTICE** are used throughout this manual to highlight important information. Be certain that the meanings of these alerts are known to all who operate and install the appliance.

 <b>DANGER</b>
Indicates a hazardous situation that, if not avoided, will result in death or serious injury.

 <b>WARNING</b>
Indicates a hazardous situation that, if not avoided, could result in death or serious injury.

 <b>CAUTION</b>
Indicates a hazardous situation that, if not avoided, could result in minor or moderate injury.

<b>NOTICE</b>
Indicates a situation that can cause damage to the appliance and/or the environment or cause the appliance to operate improperly.

## SAFETY PRECAUTIONS

### POWER CORD PRECAUTIONS

- Do not use the appliance if the power cord is damaged. If the power cord is damaged, have a qualified electrician replace the power cord.
- Never lift, carry, or drag the appliance by the power cord.
- Do not connect or disconnect the electric plug when your hands are wet.
- Never unplug the appliance by pulling on the power cord. Always grip the plug firmly and pull straight out from the outlet.

### MOVING PRECAUTIONS

- When moving the appliance, do not turn it upside-down and do not tilt it beyond a 45-degree angle.
- Do not move the appliance without emptying it and securing the door in the closed position.

### INSTALLING PRECAUTION

- Connect to a potable water supply only.

### OTHER PRECAUTIONS

- To ensure proper ventilation for the appliance, keep obstructions away from the front of the unit.

- Keep fingers out of the “pinch point” areas. Clearance between the door and cabinet are necessarily small. Be careful closing the door when children are in the area.
- Do not touch the evaporator with your hand when the appliance is operating.
- Do not attempt to repair or replace any part of your appliance unless this manual specifically recommends it. Have a qualified technician perform all other service on the unit.
- Children 8 years of age and older and people with reduced physical, sensory or mental capabilities or lack of experience and knowledge can use this appliance if they have been given supervision or instruction concerning use of the appliance in a safe way and they understand the hazards involved.
- Never allow children to operate, play with or crawl inside the appliance.
- Never allow children to clean and maintain the machine without supervision.
- Do not use the appliance other than for its intended purpose.
- Do not touch the condenser surfaces. They are sharp and can be easily damaged.

#### **CLEANING AND MAINTENANCE PRECAUTIONS**

- Never clean the appliance parts with flammable fluids. Do not store or use gasoline or other flammable vapors and liquids in the vicinity of this appliance or any other appliances. The fumes can create a fire hazard or explosion.
- Do not use solvent-based cleaning agents or abrasives on the interior. These cleaners may transmit taste to the ice cubes, or damage or discolor the interior.
- If the appliance will not be used for a long time, thoroughly clean it before the next use. Carefully follow any instructions provided for cleaning or the use of sanitizing solution. Do not leave any solution inside the appliance after cleaning.

***THE MANUFACTURER DISCLAIMS ANY RESPONSIBILITY IF THE ABOVE INSTRUCTIONS ARE NOT FOLLOWED.***

# SPECIFICATION

FEATURES	TIM1511
Electrical Requirements	115V/60Hz
Maximum Amp Fuse	15 amps
Indoor/Outdoor	Indoor/Outdoor *
IP Rating	IPX4
Ambient Operating Range	50~110°F(10°C~43°C)
Water Operating Range	40~90°F (4°C~32°C)
Water Pressure Operating Range	20~80psi (0.138MPa~0.55MPa)
Water Inlet Adapter	1/4" OD compression fitting
Ice Shape	Cube
Ice Production Capacity (70°F/50 °F)	70lbs (32Kg) **
Ice Storage Capacity	26lbs (12kg)
Ice Size (LxDxH)	7/8"x7/8"x7/8"
Ice Weight	about 0.4oz(11g) per cube
Ice quantity per cycle	32
Unit Dimensions (WxDxH)	14-7/8"x22-5/8"x32-7/ 8"
[Not Including Handle	378x574x835(mm)
Net Weight	89.2lbs (40.5Kg)

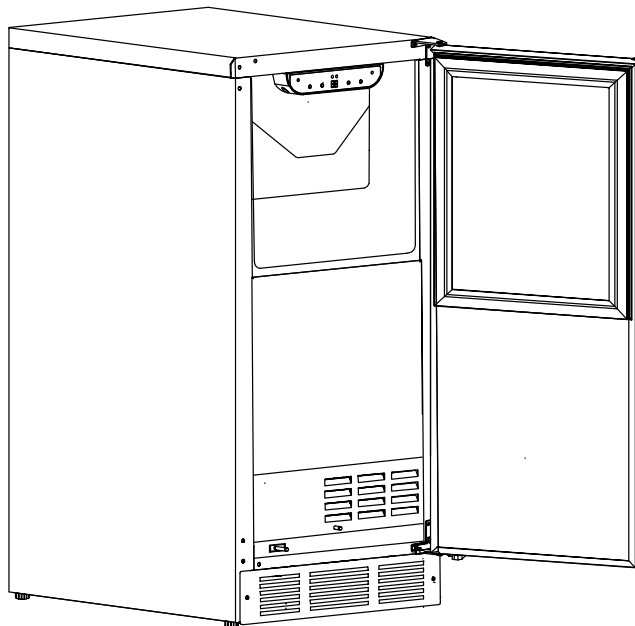

\* Within limited outdoor environment: the unit must be under the awning or the canopy and shall not be exposed directly to rain.

\*\* The actual quantity of ice produced per day will vary with ambient room and water conditions.

**Note:** Technical data and performance information are provided for reference only and subject to change.

# OPERATING THE UNIT

## **IMPORTANT: ENSURING ICE FRESHNESS AND QUALITY**

- Although the unit has been tested and cleaned at the factory, discard the first batch of ice cubes due to long-term transit and storage.
- If you do not use the ice machine regularly, the manufacturer recommends emptying the ice bin periodically to ensure ice freshness.
- The ice machine produces ice in layers resulting in a clear cube. The ice may appear wet when first produced. Ice in the bin may develop surface frost which appears when the cube is placed in liquid.

## **OTHER OPERATING TIPS**

- Keep the air intake and exhaust free of dust and lint to allow free air flow. With hard water, cleaning may have to be more frequent.
- Never touch the evaporator when the unit is running.
- Keep the door closed to reduce ice melting and to promote proper ice formation. Open the door only when taking ice from the appliance.
- Turn on the water supply tap before switching on the ice machine. Never turn the water supply tap off when the ice machine is working.

## **ICE MACHINE PRODUCTION**

Square cube ice machine TIM1511 - The ice machine will continue producing ice until the ice in the bin reaches the level indicator. Once the ice level falls below the indicator, the machine will automatically resume ice production.

# INSTALLATION

## BEFORE USING YOUR ICE MAKER

Check to be sure you have all the following parts:

- 1 Ice Scoop
- 1 Water Filter, Model#: WFIM0211
- 1 Left Latch Mechanism Kit
- 1 Use And Care Manual
- 1 Water Line

## PLUMBING AND ELECTRICAL TIPS

- A licensed plumber must install this appliance.
- This appliance must be installed with all electrical and water connections in accordance with state and local codes.
- This unit requires a standard electrical supply properly grounded in accordance with National Electrical Code and local codes and ordinances.
- The fuse (or circuit breaker) size should be 15 amperes for 115V.
- The manufacturer recommends that you provide a separate circuit that services only your appliance. Use receptacles that cannot be turned off by a switch or pull chain.
- Plug the appliance into a grounded three-prong outlet. Do not remove the grounding prong, do not use an adapter, and do not use an extension cord.
- Do not kink, pinch, or damage the power supply cord between the ice machine and wall or cabinet.
- Before connecting the ice machine to the power source, **let it stand upright for approximately 4 hours**. Following this step will reduce the possibility of a malfunction in the cooling system brought on by handling during transportation.
- Make sure to install on level surface and ensure drain line and water line are not kinked.

## TIPS ON MOVING AND SETTING UP THE UNIT

- Use two or more people to move and install the appliance. Failure to do so can result in back or other injury.
- Remove the packing materials and clean the appliance before using it.

## WATER SUPPLY TIPS

- Check for leaks after connecting the water line.
- The ice machine requires a continuous water supply with a minimum pressure of 20 psi (0.138 MPa) and a static pressure not to exceed 80 psi (0.55 MPa).
- The manufacturer recommends filtering the water. A water filter helps remove taste, odors and particles. Using softened water may result in white, mushy cubes that stick together. Avoid using deionized water.
- Using an RO filter may reduce the water pressure below the minimum level required for the ice machine to operate properly.
- Ensure that the water supply hose is not pinched, kinked, or damaged during installation.

## RECESSED INSTALLATION

A built-in installation will allow you to install the ice machine under a counter or in a kitchen cabinet

if you provide the necessary clearance space around the unit. The appliance must be positioned to allow clearance for water, drain and electrical connections in the rear of the unit.

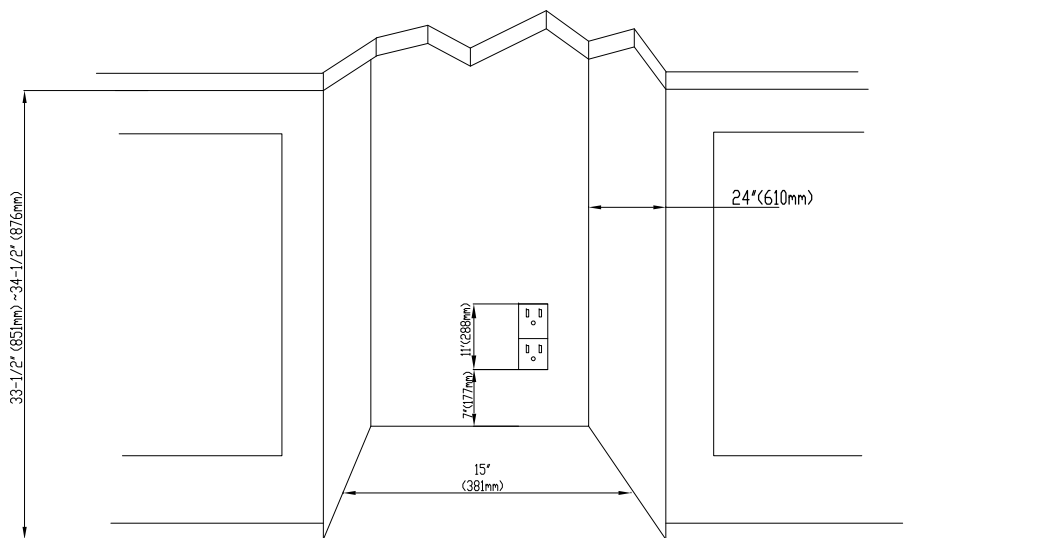

### BUILT-IN CABINET DIMENSIONS

A built-in installation requires adequate clearance for a water line and electrical plug to ensure proper operation. A built-in unit is designed for zero clearance at the top and each side of the unit. The unit uses fan-forced condenser cooling, which requires air circulation through the lower section of the unit.

To ensure proper service access and ventilation, the unit should not have the grill openings covered. There are no additional requirements for venting at the top, side, or rear of the unit.

#### NOTICE

- Ensure that the air path for the grill remains unrestricted. Any restriction of air flow through the grill will disrupt normal operation of the unit, resulting in damage to components, and voids warranty.
- **Connect the unit to a potable water supply only.**

#### ! WARNING

##### Electrical Shock Hazard

Always disconnect power at the source before working on the unit. Failure to unplug the clear ice machine could result in electrical shock or personal injury.

- Do not touch the power plug when your hands are wet.
- Never unplug the unit by pulling on the cord. Grasp the plug and pull out firmly.

### CONNECTING THE WATER SUPPLY

1. Turn off the main water supply. Turn on the nearest faucet long enough to drain the water line.
2. Locate a 1/2" to 3/4" vertical cold-water pipe within 9 feet of the installation site.

3. Install a shut-off valve to the main water supply. If the water pipe has a plain piece of copper tubing, attach a 1/4" O.D. compression union to the tubing and remove the nut.
4. Thread the nuts of the supplied water supply hose to the tap and water inlet valve. Access to the water inlet valve is through the opening in the rear panel. Tighten firmly by hand, then one-half turn with a wrench.
5. Turn on the main water supply and faucet. Check for leaks in the water supply connection. Tighten all connections.

## **FILTER INSTALLATION/REPLACEMENT**

The filter must be installed in accordance with manufacturer's recommended procedures and guidelines. To reduce the risk associated with property damage due to water leakage, you must read and follow the Installation Instructions and Use & Care Manual before installation and product operation. For replacement, contact your local dealer or place where you purchase.

### **NOTICE**

1. The filter must be replaced every 6 months, at the rated capacity or if a noticeable reduction in flow occurs.
2. Before installation or replacement, always connect the filter to the water supply separately first, and then run water for at least 5 minutes to purge the filter until the water line is clear.
3. Insert the tube to the end of the built-in quick-connectors, and Always check for leaks before fixing the filter to clips.

1. Locate the thumb screw in the lower front of the ice machine, unscrew to take away the filter panel. The water tubes are being connected by a joint connector so the ice machine CAN work without a filter.

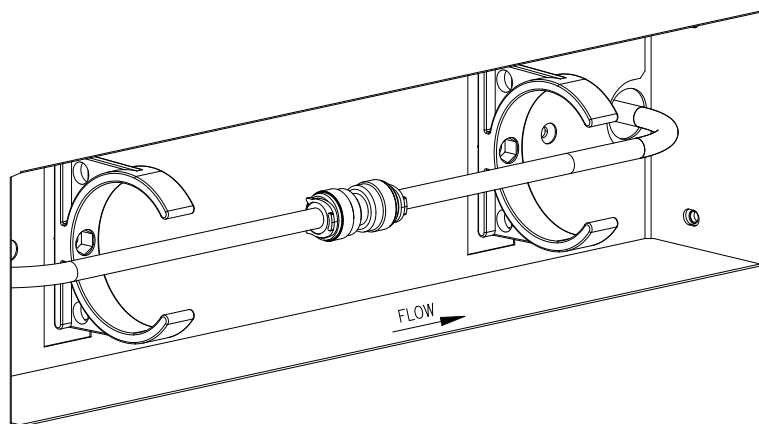

### **DO NOT TURN ON THE WATER SUPPLY BEFORE THE FILTER INSTALLATION COMPLETE!**

2. Take away the two clips on both ends of the joint connector, pull the tube out from it, and then insert the tubes to the filter's built-in 1/4" quick connectors, until the tube reaches the bottom (approx 1/2"). Turn on the water supply to check for leaks before fixing the filter to clips.

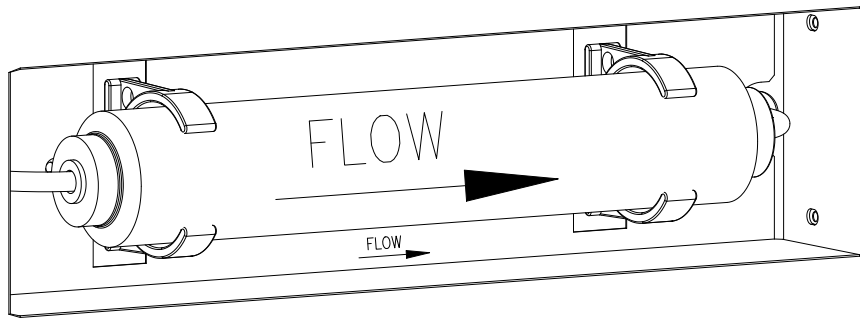

**BEWARE THE FLOW DIRECTION ARROW OF THE ICE MACHINE AND THE FILTER, MAKE SURE THEY MATCH!**

3. Put the filter panel back and tight the thumb screw firmly.

### **ELECTRICAL CONNECTION**

Do not, under any circumstances, cut or remove the third (ground) prong from the power cord.

For personal safety, you must properly ground this appliance. The power cord of this appliance features a three-prong grounding plug that mates with a standard three-prong grounding wall outlet to minimize the possibility of electric shock hazard from the appliance. Have a qualified electrician check the wall outlet and circuit to make sure the outlet is properly grounded. It is your responsibility and obligation to have a standard two-prong wall outlet replaced with a properly grounded three-prong wall outlet.

Always plug the appliance into its own individual electrical outlet. The voltage rating of the outlet must match the rating label on the appliance. This match provides the best performance and prevents overloading the electrical circuits, which could cause a fire hazard from overheated wires.

Never unplug your appliance by pulling on the power cord. Always grip the plug firmly and pull straight out from the outlet.

Repair or replace immediately all power cords that have become frayed or damaged. Do not use a cord that shows cracks or abrasion damage along its length or at either end. When moving the appliance, take care not to damage the power cord.

If the supply cord suffers damage, have the manufacturer, its service agent, or similarly qualified persons replace the supply cord to avoid a hazard.

### **AVOIDING USE OF EXTENSION CORDS**

Because of potential safety hazards under certain conditions, the manufacturer strongly recommends that you do not use an extension cord with this appliance.

### **DRAIN PUMP TIPS**

**! WARNING**

**Electrical Shock Hazard**

Be sure the floor surfaces surrounding the appliance are dry before plugging in and removing the power cord to the outlet to prevent electrical shock.

Follow these steps to test the operation of the drain pump before final installation:

1. Check the power cord and make sure it is not plugged into the outlet.
2. Place the drain hose into a suitable container that can hold at least one gallon.
3. Pour one gallon of water into the ice storage bin.
4. Plug the power cord into a properly grounded, polarized electrical outlet.
5. The drain pump should start and pump the water into the container.
6. Unplug the power cord.

## LEVELING THE UNIT

**! CAUTION**

The unit will be significantly heavier once it is operational and fully loaded.

Place your ice maker on a level surface that is strong enough to support the ice maker when it is fully loaded. Level your ice maker by adjusting the legs at the front of the ice maker. If necessary, raise or lower the unit by turning the four leveling feet on the bottom.

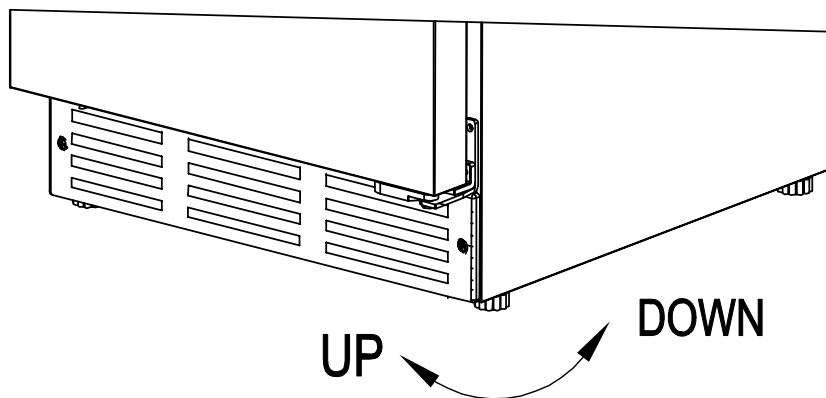

# REVERSING THE DOOR

This appliance is designed with a reversible door feature, allowing the door to open from either the left or right side. It is pre-configured for left-side opening upon delivery. If you wish to change the door opening direction, please follow the provided instructions.

## ⚠ CAUTION

Before operating, check the power cord and make sure it is not plugged into the outlet.

NOTE: THE HANDLE DOES NOT NEED TO BE REMOVED TO REVERSE THE DOOR

Tools needed: Flathead screwdriver, Phillips screwdriver

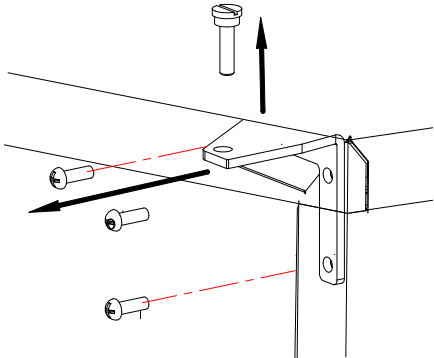
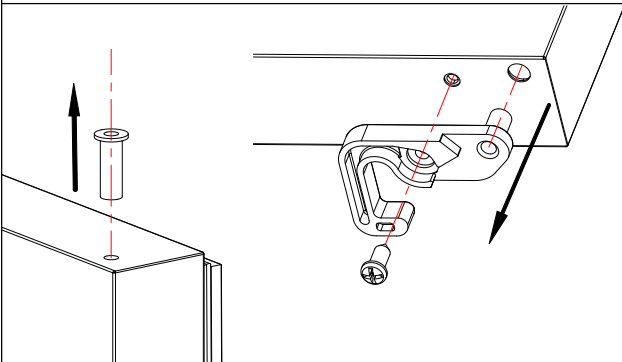
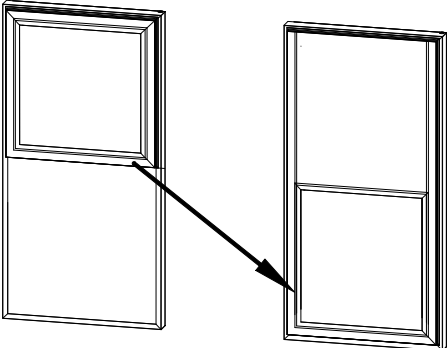
	<p>1. Use the Flathead screwdriver to unscrew the hinge pin from the top hinge, put aside, then should have an image to show this step.</p>
	<p>2. To reverse the door swing, rotate the door 180°. Begin by unscrewing and removing the right latch hook from the bottom of the door, then remove the pin sleeve from the top of the door. Next, insert the pin sleeve into the bottom of the door. Locate the left latch hook in the accessory bag and install it on the opposite side of the door.</p>
	<p>3. Carefully peel off the entire door gasket, starting from any corner, and remove the inserts from the opposite side of the door liner's mounting groove. Swap the insert positions, then attach the door gasket to the opposite side of the door. Finally, press the inserts into the exposed mounting grooves to secure them in place. The door gasket is now properly repositioned.</p>

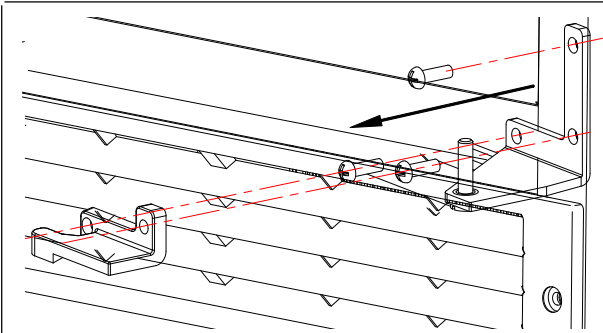

4. Use a Phillips screwdriver to remove the bolts securing the top and bottom hinges, and uninstall both hinges. Detach the right latch block from the bottom hinge and retain the removed right latch kit for future use.

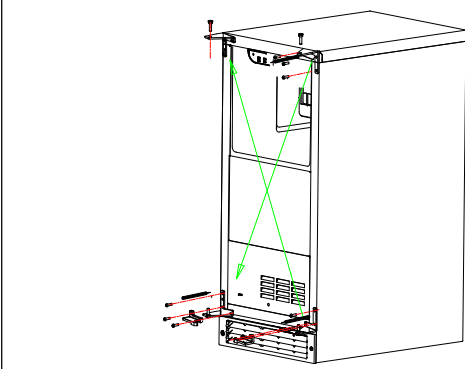

5. Swap the hinge positions by installing the bottom right hinge onto the top left of the cabinet and the top right hinge onto the bottom left of the cabinet. Use the plugs removed from the left side to cover the right-side mounting holes.

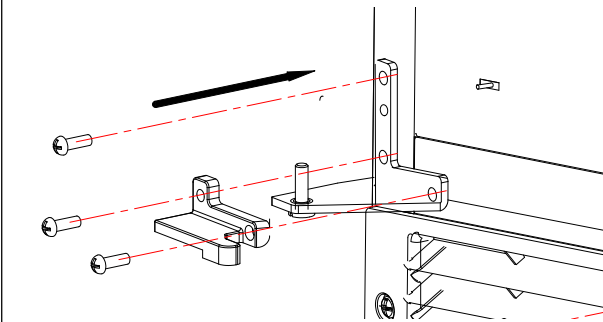







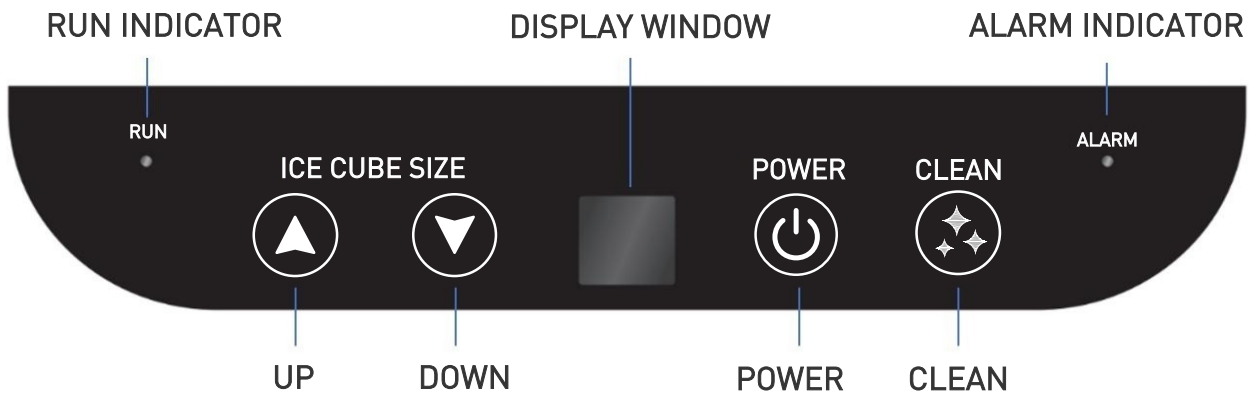





6. When installing the bottom left hinge, locate the left latch block in the accessory bag and attach it to the bottom hinge. Additionally, unscrew the hinge pin from the top left hinge to prepare for door installation.











7. Align the left latch block with the bottom hinge pin and carefully insert the door. Ensure the pin sleeve at the top of the door is properly aligned with the top hinge, then insert and securely tighten the hinge pin. The door reversal process is now complete.

# USING THE CONTROLS



The control panel, located at the top of the interior compartment, includes a display window, 4 buttons, and 2 indicator lights.

FUNCTION	OPERATING	
Turn ON		<p><b>Press the POWER button to turn ON the unit.</b></p> <p>The unit will automatically start making ice and display  during ice making and  when the ice bin is full. The RUN indicator light will illuminate..</p>
Turn OFF		<p><b>Press the POWER button to turn OFF the unit.</b></p> <p><b>This unit will enter Standby mode</b> and display .</p> <p><i>*If the unit is already in the process of making ice, it will complete the current cycle before entering Standby mode.</i></p> <p><b>Press and hold the POWER button for over 3 seconds to turn OFF the unit.</b></p> <p><i>*Incomplete ice cubes may remain in the bin if the unit is turned off while making ice.</i></p>
Adjust the ice cube size	 	<p><b>Press and hold the UP or DOWN button for over 3 seconds to enter ICE SIZE ADJUSTING mode. Then use the UP or DOWN button to change the settings.</b></p> <p>Window displays  to  (min to max).  is the default ice size.</p> <p>The setting will be saved after 5 seconds.</p>
Cleaning		<p><b>Press and hold the CLEAN button for over 3 seconds to turn ON/OFF the CLEANING mode.</b></p> <p>Once cleaning begins, the window will display , and the cleaning cycle will run for 30 minutes before exiting and then entering Standby mode.</p> <p><i>*This function can only be initiated in Standby mode.</i></p>

FUNCTION	OPERATING	
Timed Ice making	 	<p><b>Press and hold the POWER and CLEAN buttons for over 3 seconds during Standby mode to toggle ON/OFF the Timed Ice Making mode.</b></p> <p><b>When entering the time setting, press the UP or DOWN button to select a timer duration from 1 to 12 hours for the ice-making cycle.</b> The setting will automatically save after 10 seconds, and the display will show the remaining countdown time in hours.</p> <p><i>*Pressing the POWER button will skip the countdown and immediately begin the ice-making process.</i></p>
Sabbath	 	<p><b>Press and hold the UP and CLEAN buttons for over 6 seconds to toggle Sabbath mode ON/OFF.</b></p> <p>IN SABBATH mode, the display will turn off, and audible sounds will be disabled.</p>
Showroom	 	<p><b>Press and hold the DOWN and CLEAN buttons for over 6 seconds on Standby mode to toggle ON/OFF the Showroom mode.</b></p> <p>The indicator located at the bottom right of the display window will illuminate.</p> <p><i>*This mode is designed for dealer display purposes. Only the lights and display panel will operate, while all alarms are disabled except for the Door Ajar Alarm.</i></p>
Filter Reset	 	<p><b>Press and hold the UP and POWER buttons for over 6 seconds to reset the water filter.</b></p> <p>The display window will flash  and reset the filter timer.</p> <p><i>*This function can only be initiated on Standby mode. Use only after replacing the water filter.</i></p>
Firmware Version & System Recovery	 	<p><b>Press and hold the DOWN and POWER buttons to display firmware version A3.</b></p> <p><b>Holding these buttons for OVER 6 seconds will reset all settings back to default.</b></p> <p><i>*The firmware version is subject to change.</i></p>

## EXPECTING NORMAL SOUNDS

Your new ice machine may produce unfamiliar sounds during operation. Hard surfaces such as floors and walls may amplify the sounds, making them appear louder than they actually are. The following outlines the types of sounds you may hear from the ice machine and their sources. These sounds are normal part of regular operation:

- A pulsating or high-pitched sound from the high-efficiency compressor.
- A splashing sound from water running from the evaporator to the water reservoir.
- As each cycle ends, you may hear a gurgling sound caused by the refrigerant circulating within the ice machine.

- Rattling noises may result from the flow of refrigerant, the water line, or from items stored on top of the machine causing vibrations.
- You may hear the sound of the condenser fan forcing air over the condenser.
- During the harvest cycle, you may hear the sound of ice cubes falling into the ice bin.

## PANEL DISPLAY NOTIFICATION

Below notifications will sound the alarm except the Ice full stop.

Self-diagnosis Pass	88	Displayed only at the beginning of the operation process.
Filling Water	N/A	
Ice Full Stop	8F	If the ice storage bin is full, the unit will automatically stop. Remove the ice and the unit will start making ice after 3 minutes.
Door Ajar Alarm	dr	If the door remains open for more than 5 minutes, the display panel will flash <b>dr</b> with alarm sounds. All alerts will be cleared once the door is closed or any button is pressed.
Clean Reminder	CL	After approximately 6 months of operation without performing a CLEANING cycle, the panel will flash <b>CL</b> as a reminder. Run a CLEANING cycle to clear the reminder.
Filter Replace Reminder	N/A	After approximately 6 months of operation, the display panel will flash <b>Flt</b> as a reminder. Replace and reset the filter to clear the alarm.

## DEALING WITH POWER FAILURE

Most power failures are corrected within a few hours and should not affect the temperature of your ice machine if you minimize the number of times, you open the ice machine door. If the power is going to be off for a longer period of time, take the proper steps to disconnect your appliance.

**Note:** During operation, the evaporator is the only component that comes cold enough to produce ice. In the event of a power failure, only the ice-making process will be interrupted, while the ice in the bin will gradually melt as usual.

## FAULT ALARM AND ERROR CODES

When the unit detects an, an alarm will sound, the ALARM indicator will flash, and the corresponding error code will be displayed. Please provide the displayed error code when contacting customer service.

FAULT ALARM	ERROR CODES
Evaporator temperature sensor failure	E1
Condenser temperature sensor failure	E2
ICE FULL temperature sensor failure	E3
Long harvest alarm	E4
Low water alarm	E5
Drain pump failure	PU
High ambient temperature	HI

The ice machine will continue operating with the RUN indicator flashing for E1 and E2 errors, but will completely stop functioning for all other errors.

Refer to the "TROUBLESHOOTING" section for easy self-diagnosis and potential solutions to clear certain error codes.

## MAINTENANCE

### CLEANING AND MAINTAINING THE UNIT

Regular cleaning and proper maintenance are essential to maintain efficiency, optimal performance, and extend the lifespan of the machine. The maintenance intervals listed in this manual are based on normal conditions. You may want to shorten the intervals if you have pets or other special considerations.

- Periodically vacuum dust and dirt from the condenser, which is located behind the grill at the bottom front of the unit.
- Regularly inspect plumbing connections to ensure that there are no leaks.
- Disconnect the water supply hose if the ice machine will not be used for a long period of time.
- Only store ice in the ice storage bin. Storing items like wine or beer bottles is unsanitary.

### CLEANING THE UNIT'S EXTERIOR

Clean the door and cabinet using a mild detergent and warm-water solution, such as 1oz. (28g) of dishwashing liquid mixed with 2 gallons of warm water. Do not use solvent-based or abrasive cleaners. Use a soft sponge and rinse the unit with clean water. Wipe the unit down with a soft, clean towel to prevent water spots.

For stainless steel surfaces, use a mild-detergent, warm water, and a damp cloth. Do not use abrasive cleaning agents.

### CLEANING THE UNIT'S INTERIOR

When necessary, defrost and thoroughly clean the inside of the unit with mild soap and water. Do not use electrical heating devices or sharp or pointed tools when defrosting the unit.

When defrosting or leaving the unit turned off, leave the door open. Leaving the door open allows air to circulate and dry the interior, reducing the risk of mildew and preventing damage to the mold mechanism's components.

## EXTENDED PERIODS OF NON-USE



### **WARNING**

#### **Electrical Shock Hazard**

Always disconnect power at the source before working on the unit.

Note: Do not winterize this unit with ANY type of anti-freeze; damage to the mold coating will occur, invalidating product's Limited Warranty and creating a potential health hazard.

1. Turn off the water at the main water source.
2. Disconnect the water supply line from the water inlet of the ice machine.
3. Turn off the electric supply at the main power source. Remove the power cord from the electrical outlet.
4. Remove any remaining ice from the storage bin.
5. Press and hold the CLEAN button for 3 seconds to run a CLEAN cycle and drain all the water from the water trough. Once the cycle is complete, turn off the unit.
6. Leave the door open to allow for air circulation to prevent mold and mildew.
7. Leave the water supply line disconnected and the power cord unplugged until ready to use.

**NOTICE:** Never pull on the power cord to unplug the appliance from the electrical outlet. Firmly grasp the power cord plug and pull it straight out.

## RECOMMISSIONING THE UNIT

1. Connect the water supply lines, turn on the water, check for leaks, and then restore power to the unit.
2. Once water has filled the trough, ice making cycles will commence.

## STARTING UP THE UNIT

1. Replace the filter, turn on the water, check for leaks, and then turn on power.
2. Turn on the unit by pressing the power button.
3. The water inlet valve will turn on immediately to supply water to the unit. The water pump and compressor will turn on later (approximately 5 minutes) to initiate the ice-making cycle. If the machine was shut-off while in the ice-harvesting cycle, make sure the ice is harvested before starting up the unit.
4. The first harvest of ice should occur within 60 minutes of start-up.
5. Once the unit purges air from the lines, it will proceed with normal ice harvesting and refilling cycles approximately every 40 minutes or less, under typical operating conditions.

# TROUBLESHOOTING

## Before Calling for Service:

If the unit appears to be malfunctioning, read through the “OPERATING THE UNIT” section of this manual first. If the issue persists, check the Troubleshooting Guide below. Some of the problems mentioned in the Troubleshooting Guide can be easily solved without a service call.

PROBLEM	POSSIBLE CAUSES	SOLUTIONS
<ul style="list-style-type: none"> <li>The machine won't operate.</li> </ul>	<ul style="list-style-type: none"> <li>The ice machine is unplugged.</li> <li>The ice machine power switch is OFF.</li> <li>The ice storage bin is full of ice.</li> </ul>	<ul style="list-style-type: none"> <li>Plug the ice machine in.</li> <li>Verify that the control unit is properly programmed.</li> <li>Remove some of the ice.</li> </ul>
<ul style="list-style-type: none"> <li>The compressor is operating abnormally and producing a buzzing noise.</li> </ul>	<ul style="list-style-type: none"> <li>The voltage is lower than recommended.</li> </ul>	<ul style="list-style-type: none"> <li>Stop the ice machine and do not restart until the voltage is normal.</li> </ul>
<ul style="list-style-type: none"> <li>The water does not flow into the machine after startup. (Possible error codes: E4/E5)</li> </ul>	<ul style="list-style-type: none"> <li>The water supply tap is turned off.</li> <li>The water supply pipe is not properly connected.</li> <li>The water filter is not installed or not installed correctly.</li> <li>Water inlet valve malfunction.</li> </ul>	<ul style="list-style-type: none"> <li>Turn on the water supply tap.</li> <li>Reconnect the water supply pipe.</li> <li>Check that the water filter is installed correctly.</li> <li>Contact Service.</li> </ul>
<ul style="list-style-type: none"> <li>Machine makes ice, but at a very slow rate. (possible error codes HI).</li> </ul>	<ul style="list-style-type: none"> <li>The condenser may be dirty.</li> <li>The air flow to the ice machine may be obstructed.</li> <li>The ambient temperature and water temperature are high, or the unit is positioned near a heat source.</li> </ul>	<ul style="list-style-type: none"> <li>Clean the condenser.</li> <li>Check the installation to ensure the air flow to the ice maker is not blocked.</li> <li>Check the installation to ensure the ambient temperature is in the proper range.</li> </ul>
<ul style="list-style-type: none"> <li>Water is leaking out of the unit. (Possible error codes: E4/E5)</li> </ul>	<ul style="list-style-type: none"> <li>A few water droplets are on the door.</li> <li>The water supply connection is leaking.</li> <li>Incorrect filter installation.</li> </ul>	<ul style="list-style-type: none"> <li>Under certain conditions, humidity may condense on the door. To reduce condensation, consider relocating the unit or minimizing the frequency of door openings.</li> <li>Tighten water supply hosefitting.</li> <li>Check that the water filter is installed correctly.</li> </ul>
<ul style="list-style-type: none"> <li>Ice cubes are partially formed and appear white at the bottom. (Possible error codes: E4/E5)</li> </ul>	<ul style="list-style-type: none"> <li>There is not enough water in the water bin.</li> </ul>	<ul style="list-style-type: none"> <li>Check if the water supply pressure is below 20 psi.</li> <li>Check the water supply. It may be restricted.</li> <li>Check for a water leak at the water trough.</li> </ul>

PROBLEM	POSSIBLE CAUSES	SOLUTIONS
<ul style="list-style-type: none"> <li>Noise during operation.</li> </ul>	<ul style="list-style-type: none"> <li>The feet are not leveled.</li> <li>Certain sounds are normal.</li> </ul>	<ul style="list-style-type: none"> <li>Level the feet. See "LEVELING THE UNIT".</li> <li>See "EXPECTING NORMAL SOUNDS".</li> </ul>
<ul style="list-style-type: none"> <li>The ice made is too large and has pieces sticking together.</li> </ul>	<ul style="list-style-type: none"> <li>The water temperature in the storage tray or the ambient temperature is too low.</li> </ul>	<ul style="list-style-type: none"> <li>Stop the machine and reset the ice-making cycle.</li> <li>Restart the machine after turning it off.</li> </ul>
<ul style="list-style-type: none"> <li>Ice-making conditions are correct, but no ice is being produced.</li> </ul>	<ul style="list-style-type: none"> <li>The refrigerant leaks and/or the sealed system is blocked.</li> <li>Water pressure is not properly set.</li> </ul>	<ul style="list-style-type: none"> <li>Contact Service.</li> <li>The recommended water pressure is 58 psi. Pressures must not fall below 20 psi and static pressure must not exceed 80 psi.</li> </ul>
<ul style="list-style-type: none"> <li>The ice machine stops unexpectedly during the ice-making process.</li> </ul>	<ul style="list-style-type: none"> <li>The electricity is off.</li> <li>The room temperature is out of the stated range.</li> </ul>	<ul style="list-style-type: none"> <li>Reconnect the power supply line.</li> <li>Disconnect the power and allow the ice machine to remain off until the temperature returns to the specified range.</li> </ul>
<ul style="list-style-type: none"> <li>The body of the ice machine is electrified.</li> </ul>	<ul style="list-style-type: none"> <li>The grounding line is not properly connected to the socket.</li> </ul>	<ul style="list-style-type: none"> <li>Use the correct plug and outlet.</li> </ul>
<ul style="list-style-type: none"> <li>Mineral scale accumulates rapidly inside the machine.</li> </ul>	<ul style="list-style-type: none"> <li>The calcium level in the water is too high.</li> </ul>	<ul style="list-style-type: none"> <li>Install a water softener at the water inlet valve to reduce mineral buildup.</li> </ul>

# WARRANTY



# THOR

K I T C H E N<sup>®</sup>

## Warranty & Service

This product has been manufactured by Thor International, 4651 E Airport Dr, Ontario, CA 91761

---

For Customer Service, please call (877) 288 - 8099

For the most up to date warranty and service policy, please refer to our website  
[WWW.THORKITCHEN.COM/WARRANTY-REGISTRATION](http://WWW.THORKITCHEN.COM/WARRANTY-REGISTRATION)

For in-warranty service requests, please visit our website at  
[WWW.THORKITCHEN.COM/SERVICE](http://WWW.THORKITCHEN.COM/SERVICE)

Please Note: You must provide proof of purchase or installation date for any in-warranty service requests

# We Stand Behind the Quality of Our Appliances.



Reliability and customer satisfaction are our top priorities. We offer a solid two-year warranty on both parts and labor. Enjoy professional-grade performance with the confidence that we've got you covered.

## Warranty Registration Made Easy.

**01** Scan the QR Code or visit [thorkitchen.com/register-your-product](http://thorkitchen.com/register-your-product).

**02** Input your purchase and product information and select register.

**03** That's it. You're all set. Enjoy!

Questions: [service@thorinternational.com](mailto:service@thorinternational.com)



WARRANTY



PARTS

