



# 5.2 cu. ft. Undercounter Beverage Center

WUB50X24H



Fingerprint-Resistant Stainless  
WUB50X24HZ

## Capacity

Total Capacity	5.2 cu. ft
----------------	------------

## General Features & Properties

Reversible Glass Door	
-----------------------	--

Temperature Sensor Alert	
--------------------------	--

Fingerprint Resistant	
-----------------------	--

Electronic Temperature Controls	
---------------------------------	--

## Electrical Details

Amps	15 or 20
------	----------

Volts	115
-------	-----

## Certifications

ENERGY STAR® Certified	Yes
------------------------	-----

## Technical Details

Refrigerator Type	Undercounter
-------------------	--------------

Number of Shelves	1 Adjustable, 1 Fixed
-------------------	--------------------------

Number of Racks	2
-----------------	---

Lighting Type	LED
---------------	-----

Control Location	Center Divider
------------------	-------------------

Installation Option	Freestanding or Built-In
---------------------	-----------------------------

## Dimensions

Product Dimensions (H x W x D)	34-1/2" x 23-15/16" x 25-5/8"
-----------------------------------	-------------------------------------

Depth with Door Open 90°	46-1/4"
--------------------------	---------

Cutout Dimensions (H x W)	34-1/2" x 24"
------------------------------	------------------

## Reference Material

[Dimension Guide](#)

[Use & Care Guide](#)

[Energy Guide](#)

[Warranty](#)

### Also available in:

-  Fingerprint-Resistant Black Stainless **WUB50X24HV**

## Key Features & Benefits

### LED Interior Lighting

Keep drinks looking as good as they taste. Light is cast inside so everything looks like it's supposed to.

### Wine Storage

Conveniently store up to 14 bottles of wine in a designated area.

### Dual-Temperature Controlled Zone

Customize up to two different temperatures to accommodate whatever beverages you're storing.

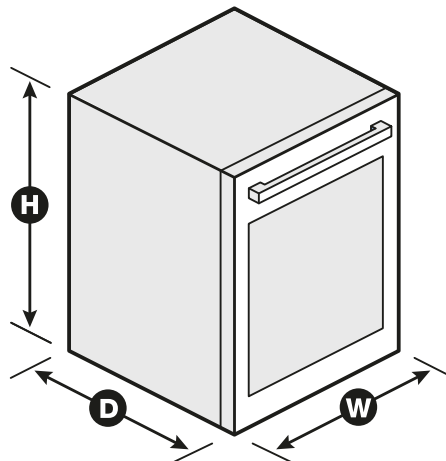

NOTE: Dimensions are for planning purposes only. For complete details, see Installation Instructions packed with product. Specifications subject to change without notice.

®/™ © 2020. All rights reserved. Printed in the U.S.A. D200052XXC. WUB50X24HSPECSHEETV01.